

Number of Students : 19

**Multiple Choice**

**Reading**

School  
District  
Province

**Mark**

73.3  
71.4  
72.7

School  
vs  
District



School  
vs  
Province



**Closed Responses\***

**Demand Writing (Creative)**

School  
District  
Province

66.7  
66.5  
68.0



**Demand Writing (Persuasive)**

School  
District  
Province

73.3  
61.0  
60.8



**Non - Fiction Reading**

School  
District  
Province

88.9  
79.9  
80.1



**Fiction Reading**

School  
District  
Province

76.5  
62.1  
65.1



\* How to interpret the results for Closed Responses

On the Demand Writing (Creative) section, the students in Copper Ridge Academy scored 66.7%. This means 66.7% of the students met or exceeded the cut score for this section.

4 Year CRT (Subtest) Mark Trend 2010-2013  
Multiple Choice

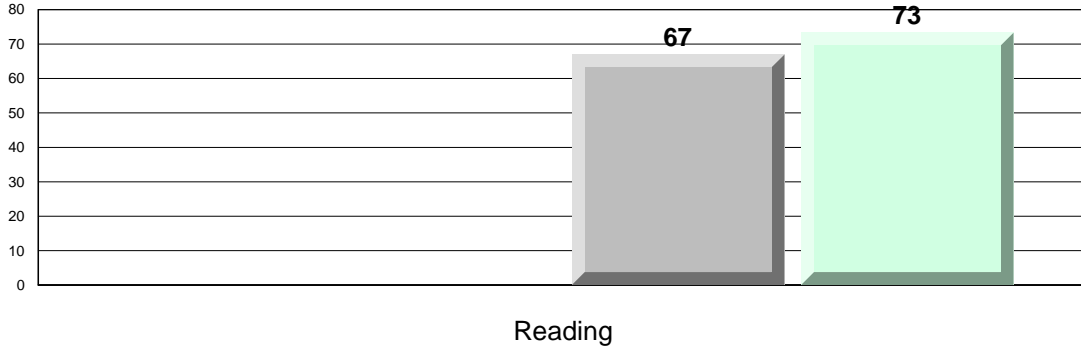

Written Response: Percentage of students meeting/exceeding grade level expectations 2010-2013

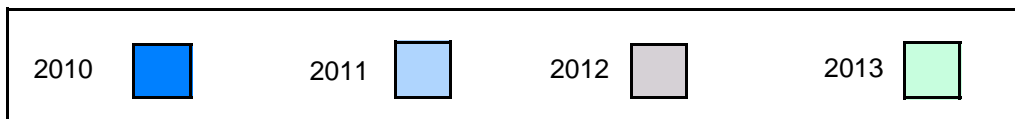
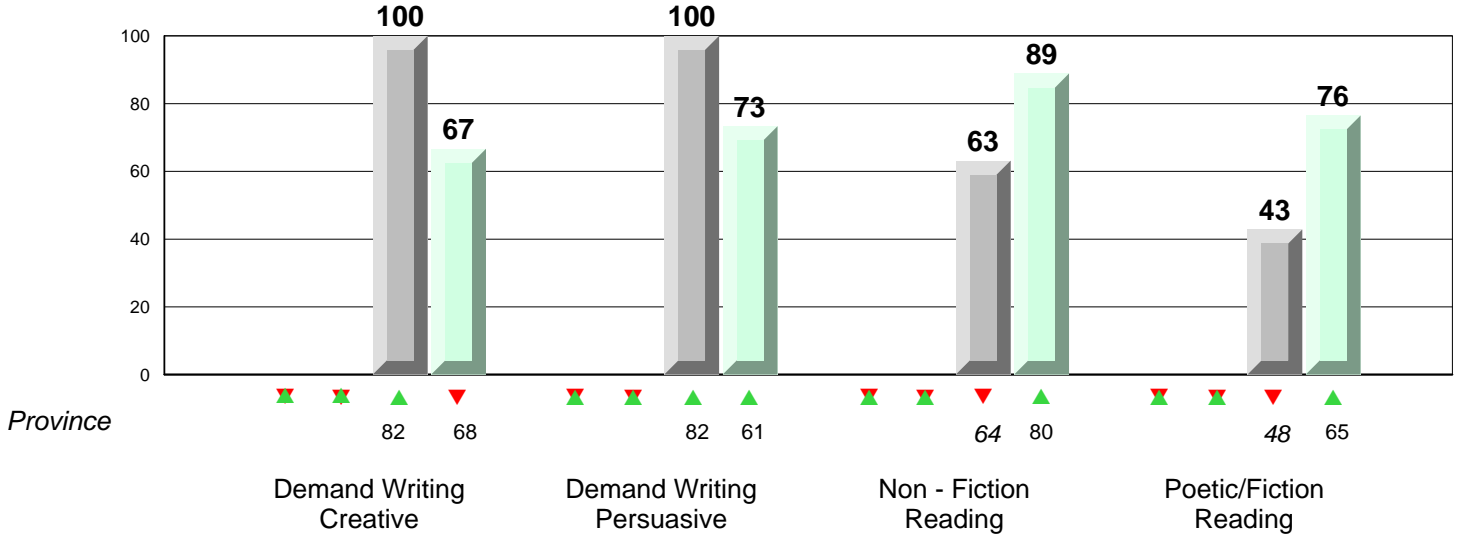

**Difference from Provincial Mean, 2010-13**

Multiple Choice

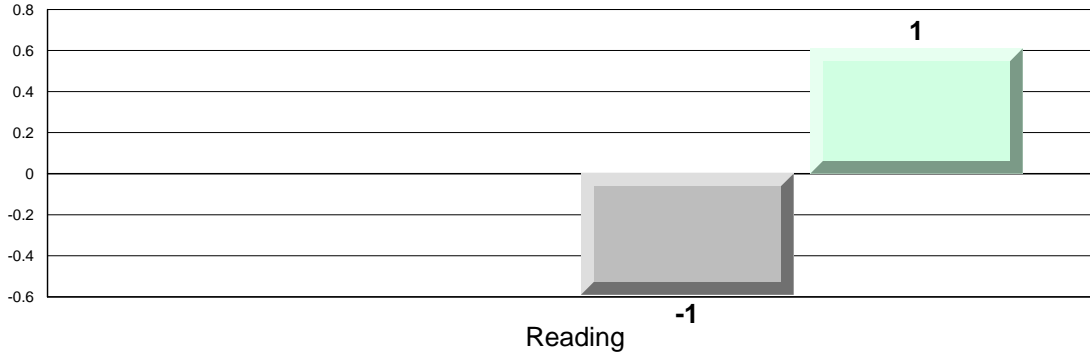

**Difference from Provincial Mean, 2010-13**

Written Response: Percentage of students meeting/exceeding grade level expectations 2010-2013

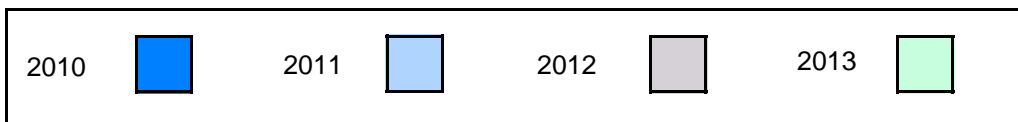
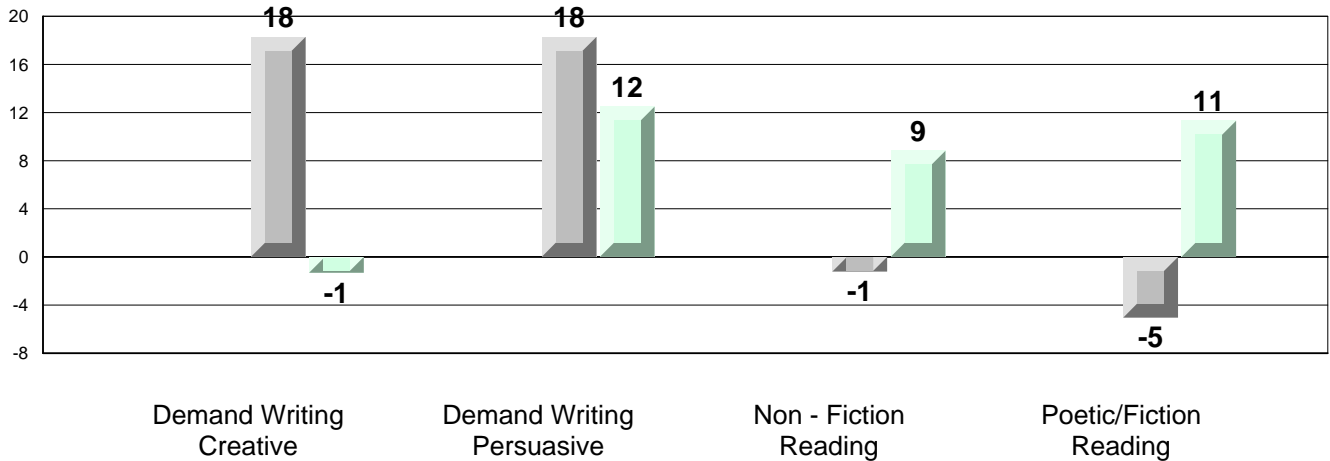

Number of Students : 45

**Multiple Choice**

**Reading**

School  
District  
Province

**Mark**

School  
vs  
District

School  
vs  
Province

69.4  
71.4  
72.7



**Closed Responses\***

**Demand Writing (Creative)**

School  
District  
Province

63.4  
66.5  
68.0



**Demand Writing (Persuasive)**

School  
District  
Province

50.0  
61.0  
60.8



**Non - Fiction Reading**

School  
District  
Province

79.4  
79.9  
80.1



**Fiction Reading**

School  
District  
Province

48.6  
62.1  
65.1



\* How to interpret the results for Closed Responses

On the Demand Writing (Creative) section, the students in Memorial Academy scored 63.4%. This means 63.4% of the students met or exceeded the cut score for this section.

4 Year CRT (Subtest) Mark Trend 2010-2013  
Multiple Choice

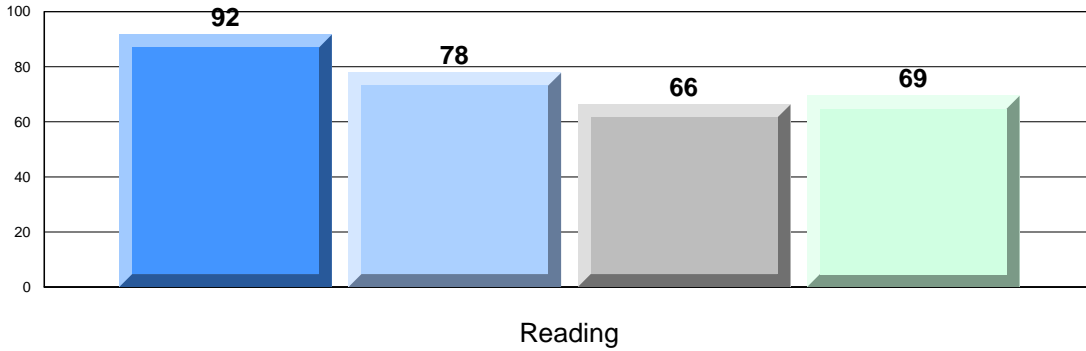

Written Response: Percentage of students meeting/exceeding grade level expectations 2010-2013

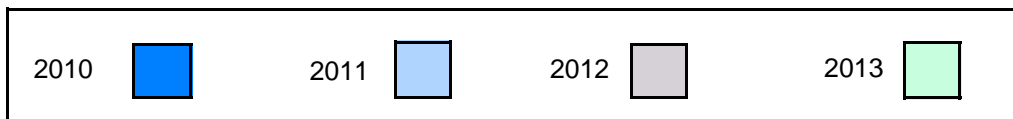
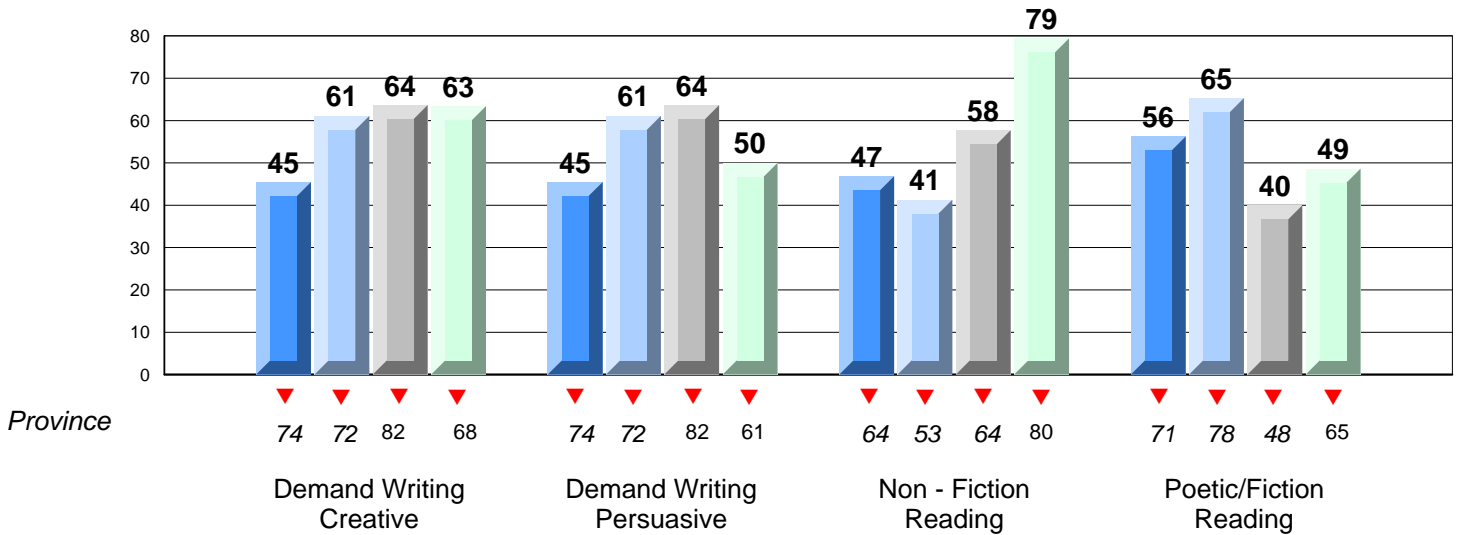

**Difference from Provincial Mean, 2010-13**

Multiple Choice

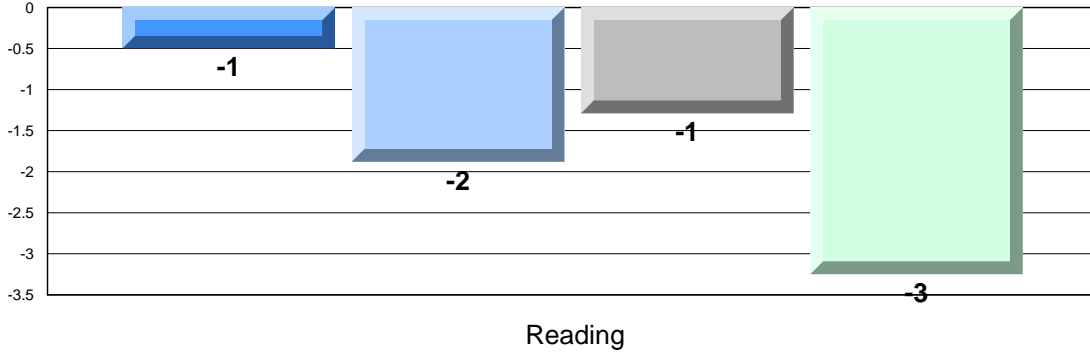

**Difference from Provincial Mean, 2010-13**

Written Response: Percentage of students meeting/exceeding grade level expectations 2010-2013

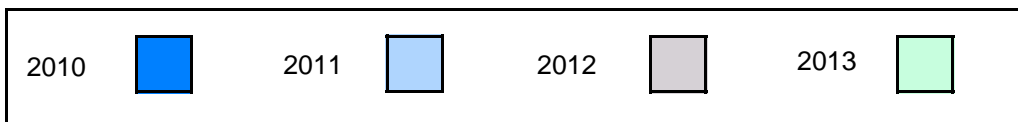
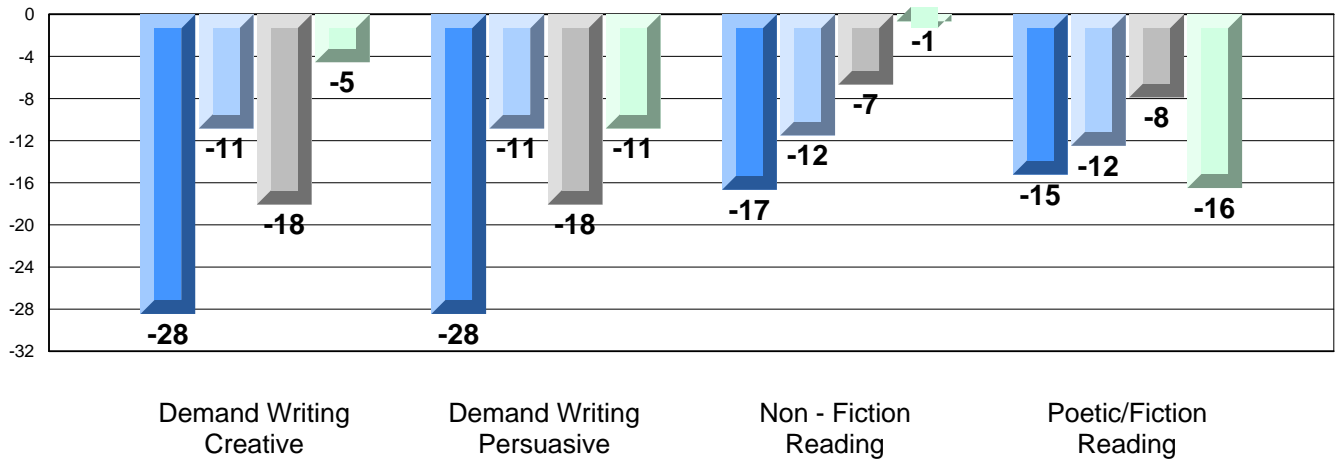

Number of Students : 2

**Multiple Choice**

**Reading**

School  
District  
Province

Mark	School vs District	School vs Province
School data with 5 or fewer students withheld for reasons of confidentiality.	▲	▼

**Closed Responses\***

**Demand Writing (Creative)**

School  
District  
Province

▲

▲

**Demand Writing (Persuasive)**

School  
District  
Province

▲

▲

**Non - Fiction Reading**

School  
District  
Province

▲

▲

**Fiction Reading**

School  
District  
Province

▼

▼

\* How to interpret the results for Closed Responses

On the Demand Writing (Creative) section, the students in Victoria Academy scored 100.0%. This means 100.0% of the students met or exceeded the cut score for this section.

**4 Year CRT (Subtest) Mark Trend 2010-2013**  
**Multiple Choice**

School data with 5 or fewer students withheld for reasons of confidentiality.

Reading

**Written Response: Percentage of students meeting/exceeding grade level expectations 2010-2013**

School data with 5 or fewer students withheld for reasons of confidentiality.

Province	2010	2011	2012	2013
Demand Writing Creative	74 ▲	72 ▲	82 ▲	68 ▲
Demand Writing Persuasive	74 ▲	72 ▲	82 ▲	61 ▲
Non - Fiction Reading	64 ▲	53 ▲	64 ▲	80 ▲
Poetic/Fiction Reading	71 ▲	78 ▲	48 ▲	65 ▼

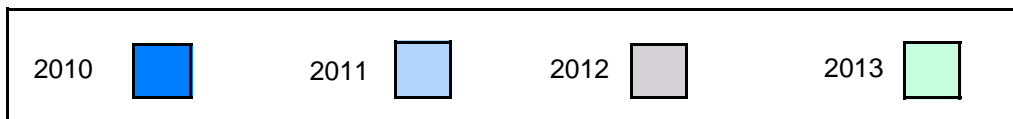



**Difference from Provincial Mean, 2010-13**

Multiple Choice

School data with 5 or fewer students withheld for reasons of confidentiality.

Reading

**Difference from Provincial Mean, 2010-13**

**Written Response: Percentage of students meeting/exceeding grade level expectations 2010-2013**

School data with 5 or fewer students withheld for reasons of confidentiality.

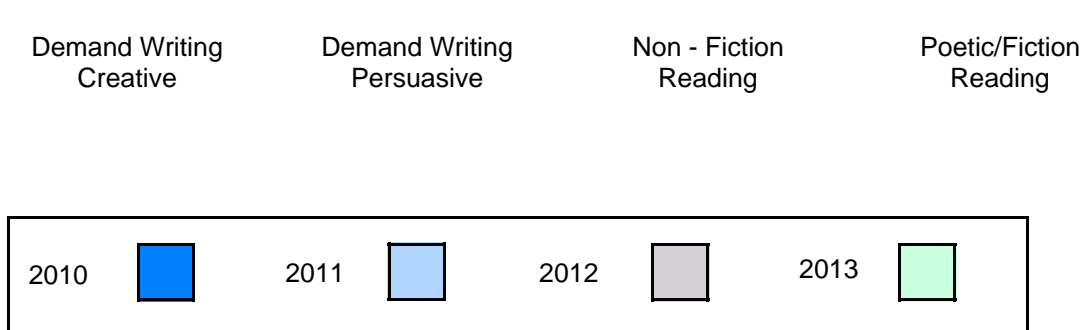

Number of Students : 85

**Multiple Choice**

**Reading**

School  
District  
Province

**Mark**

74.7  
71.4  
72.7

School  
vs  
District



School  
vs  
Province



**Closed Responses\***

**Demand Writing (Creative)**

School  
District  
Province

59.8  
66.5  
68.0



**Demand Writing (Persuasive)**

School  
District  
Province

60.8  
61.0  
60.8



**Non - Fiction Reading**

School  
District  
Province

93.3  
79.9  
80.1



**Fiction Reading**

School  
District  
Province

76.2  
62.1  
65.1



\* How to interpret the results for Closed Responses

On the Demand Writing (Creative) section, the students in Woodland Primary scored 59.8%. This means 59.8% of the students met or exceeded the cut score for this section.

4 Year CRT (Subtest) Mark Trend 2010-2013  
Multiple Choice

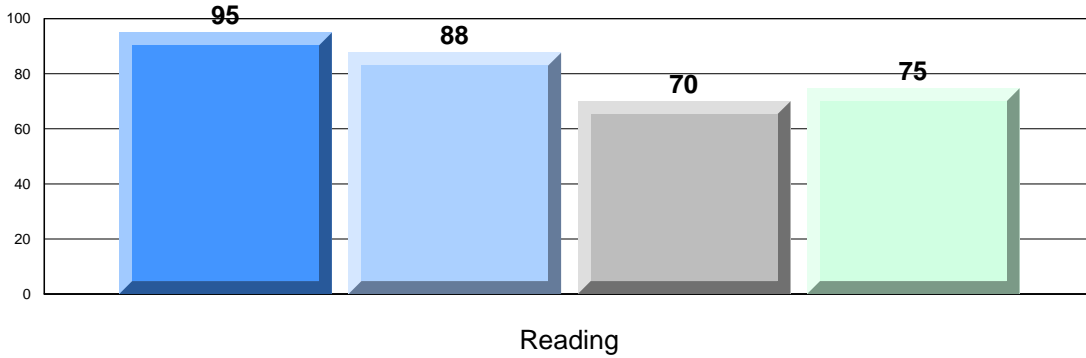

Written Response: Percentage of students meeting/exceeding grade level expectations 2010-2013

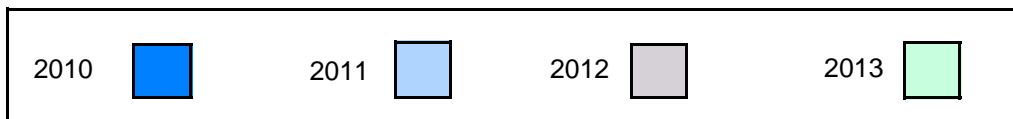
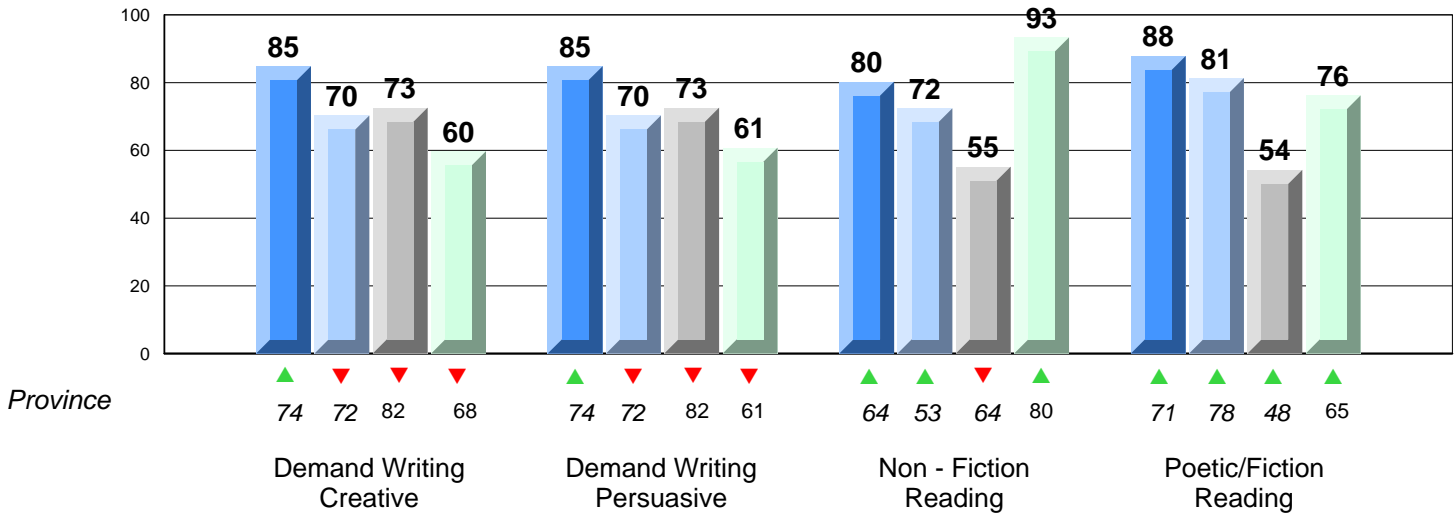

**Difference from Provincial Mean, 2010-13**

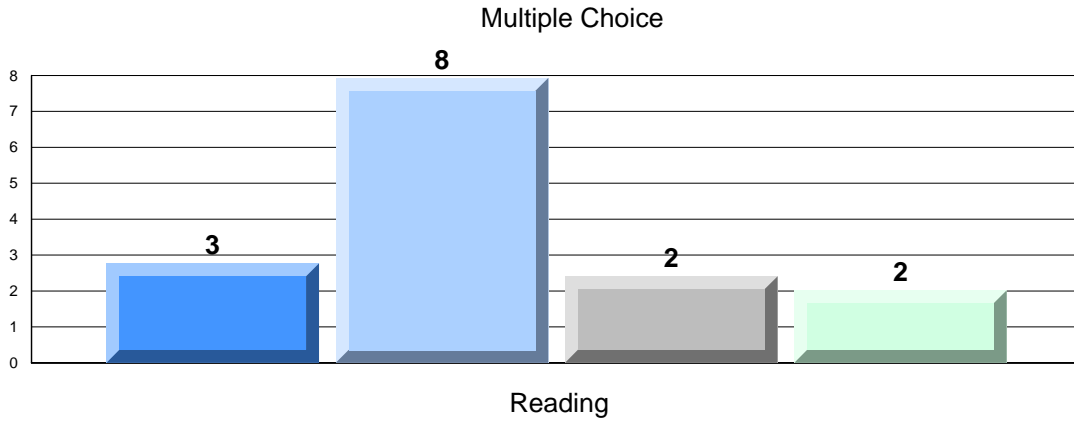

**Difference from Provincial Mean, 2010-13**

**Written Response: Percentage of students meeting/exceeding grade level expectations 2010-2013**

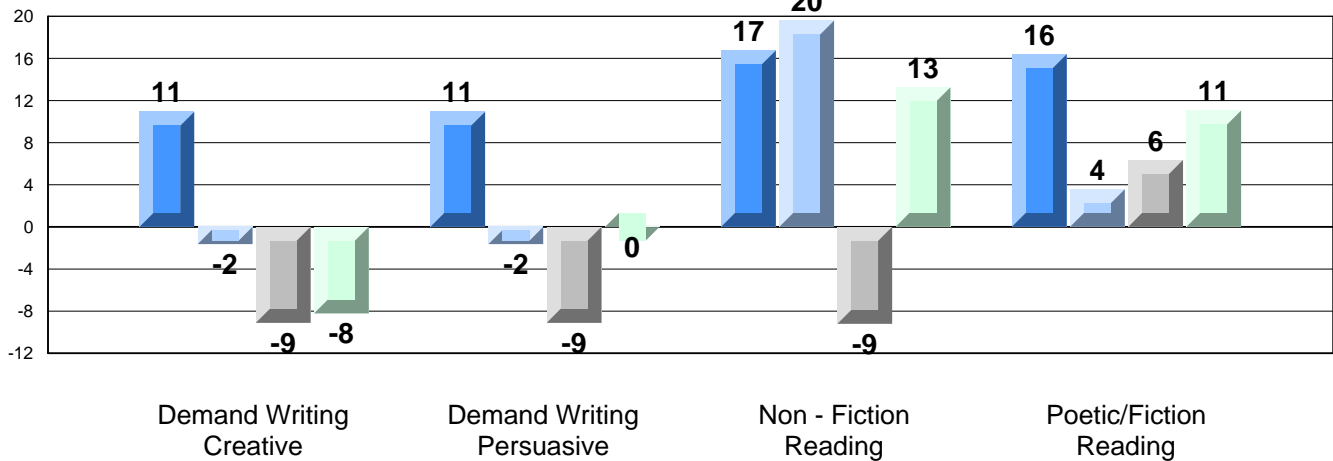

Number of Students : 43

**Multiple Choice**

**Reading**

School  
District  
Province

**Mark**

School  
vs  
District

School  
vs  
Province

77.7  
71.4  
72.7



**Closed Responses\***

**Demand Writing (Creative)**

School  
District  
Province

76.2  
66.5  
68.0



**Demand Writing (Persuasive)**

School  
District  
Province

87.8  
61.0  
60.8



**Non - Fiction Reading**

School  
District  
Province

94.6  
79.9  
80.1



**Fiction Reading**

School  
District  
Province

84.2  
62.1  
65.1



\* How to interpret the results for Closed Responses

On the Demand Writing (Creative) section, the students in Sprucewood Academy scored 76.2%. This means 76.2% of the students met or exceeded the cut score for this section.

4 Year CRT (Subtest) Mark Trend 2010-2013  
Multiple Choice

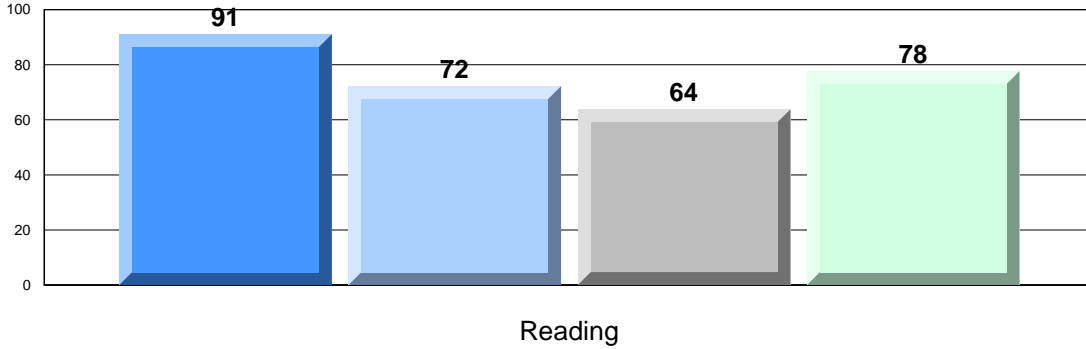

Written Response: Percentage of students meeting/exceeding grade level expectations 2010-2013

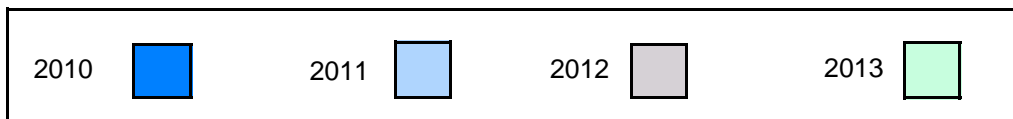
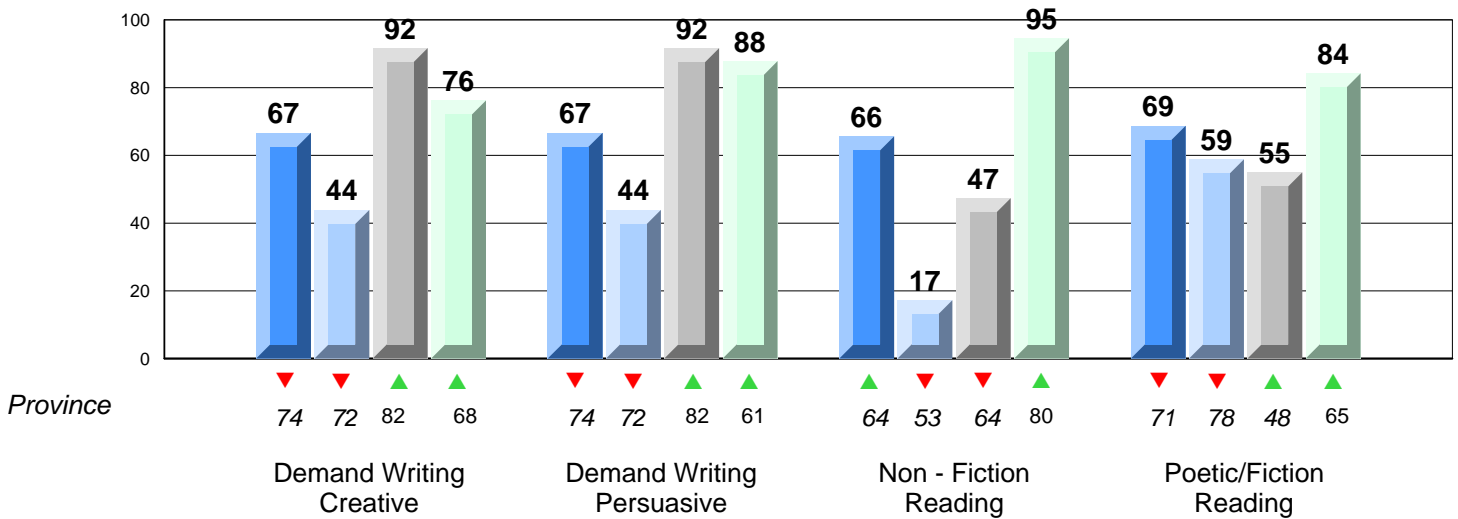

**Difference from Provincial Mean, 2010-13**

Multiple Choice

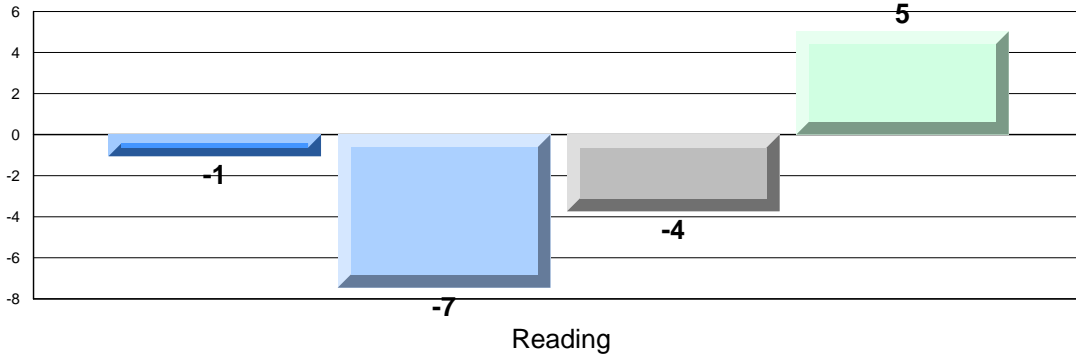

**Difference from Provincial Mean, 2010-13**

Written Response: Percentage of students meeting/exceeding grade level expectations 2010-2013

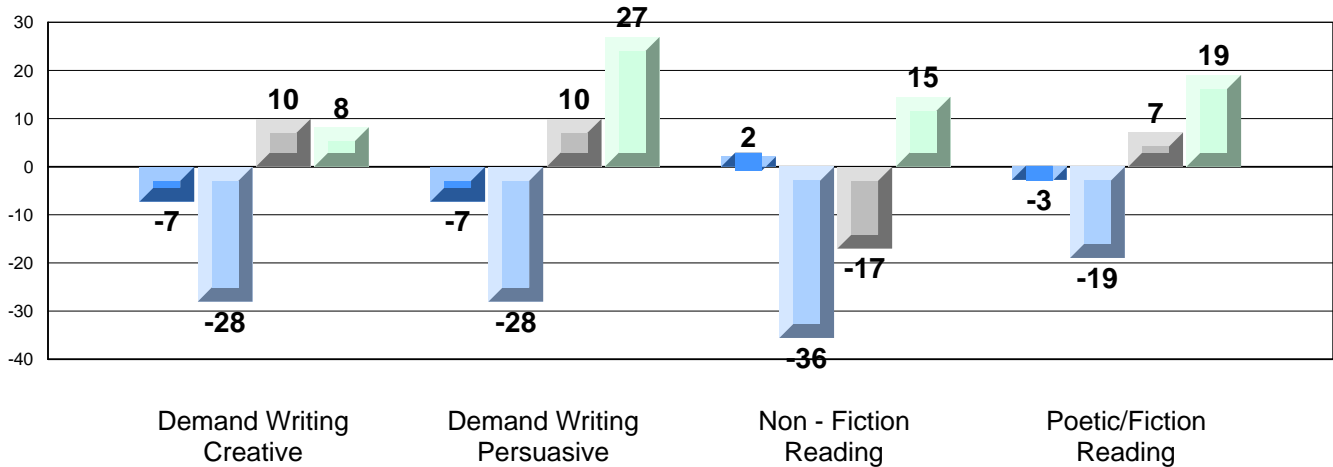

Number of Students : 18

**Multiple Choice**

**Reading**

School  
District  
Province

**Mark**

64.8  
71.4  
72.7

School  
vs  
District



School  
vs  
Province



**Closed Responses\***

**Demand Writing (Creative)**

School  
District  
Province

56.3  
66.5  
68.0



**Demand Writing (Persuasive)**

School  
District  
Province

37.5  
61.0  
60.8



**Non - Fiction Reading**

School  
District  
Province

57.1  
79.9  
80.1



**Fiction Reading**

School  
District  
Province

50.0  
62.1  
65.1



\* How to interpret the results for Closed Responses

On the Demand Writing (Creative) section, the students in St. Joseph's Elementary scored 56.3%. This means 56.3% of the students met or exceeded the cut score for this section.



4 Year CRT (Subtest) Mark Trend 2010-2013  
Multiple Choice

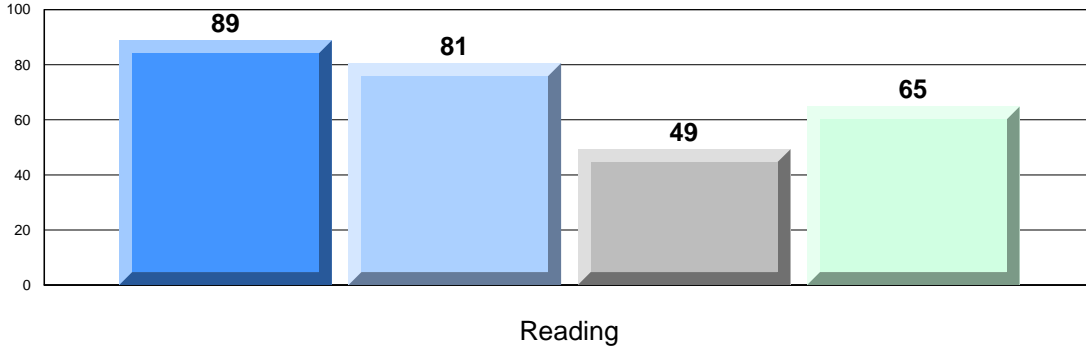

Written Response: Percentage of students meeting/exceeding grade level expectations 2010-2013

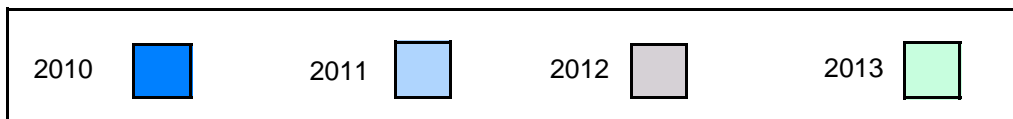
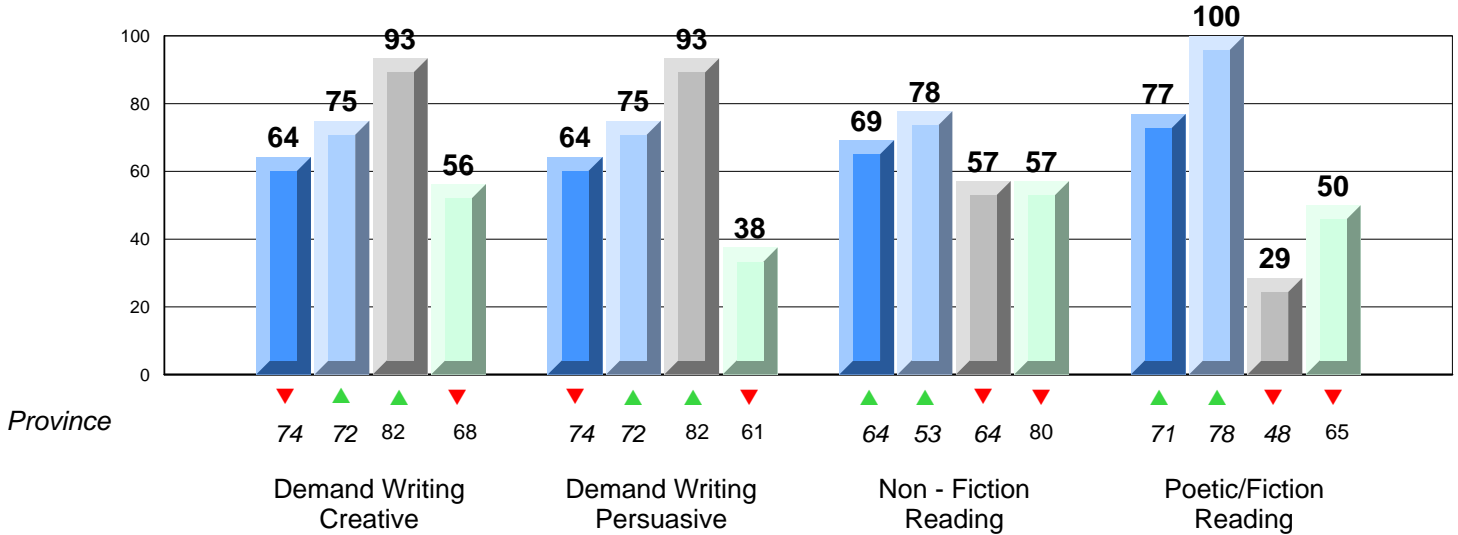

**Difference from Provincial Mean, 2010-13**

Multiple Choice

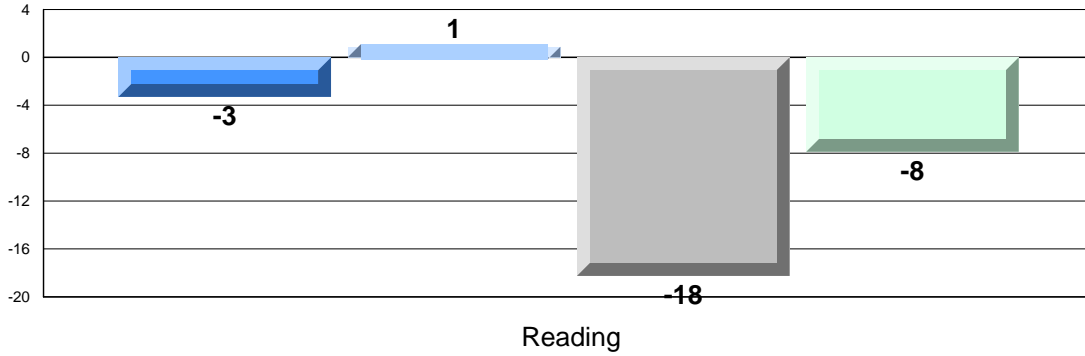

**Difference from Provincial Mean, 2010-13**

Written Response: Percentage of students meeting/exceeding grade level expectations 2010-2013

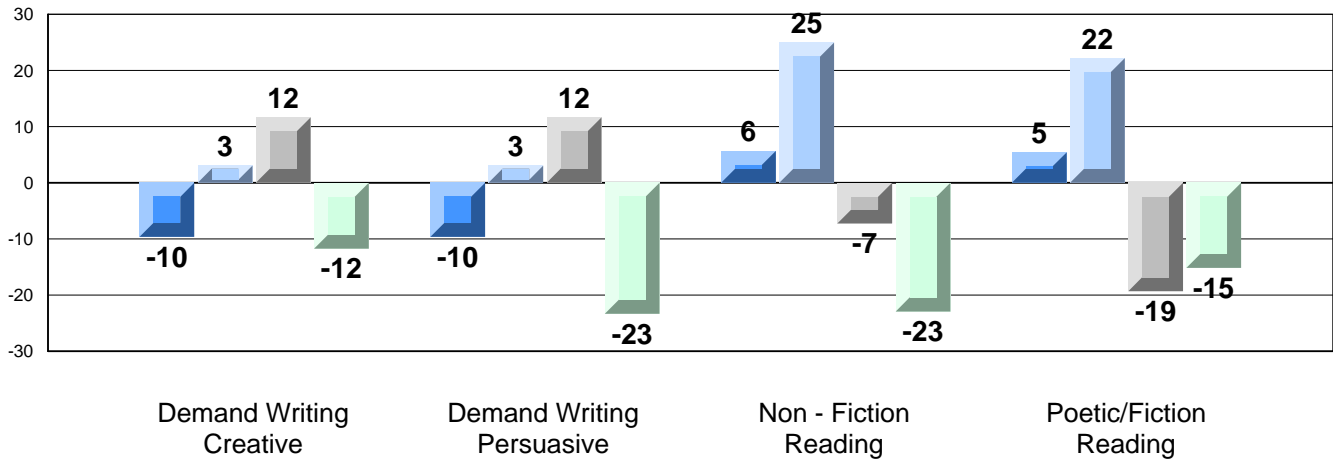

Number of Students : 3

**Multiple Choice**

**Reading**

School  
District  
Province

Mark	School vs District	School vs Province
School data with 5 or fewer students withheld for reasons of confidentiality.	▼	▼

**Closed Responses\***

**Demand Writing (Creative)**

School  
District  
Province

▼

▼

**Demand Writing (Persuasive)**

School  
District  
Province

▲

▲

**Non - Fiction Reading**

School  
District  
Province

▼

▼

**Fiction Reading**

School  
District  
Province

▼

▼

\* How to interpret the results for Closed Responses

On the Demand Writing (Creative) section, the students in John Watkins Academy scored 50.0%. This means 50.0% of the students met or exceeded the cut score for this section.

**4 Year CRT (Subtest) Mark Trend 2010-2013**  
**Multiple Choice**

School data with 5 or fewer students withheld for reasons of confidentiality.

Reading

**Written Response: Percentage of students meeting/exceeding grade level expectations 2010-2013**

School data with 5 or fewer students withheld for reasons of confidentiality.

Province	2010	2011	2012	2013
Demand Writing Creative	74 ▲	72 ▼	82 ▲	68 ▼
Demand Writing Persuasive	74 ▲	72 ▼	82 ▲	61 ▲
Non - Fiction Reading	64 ▼	53 ▼	64 ▲	80 ▼
Poetic/Fiction Reading	71 ▲	78 ▼	48 ▲	65 ▼

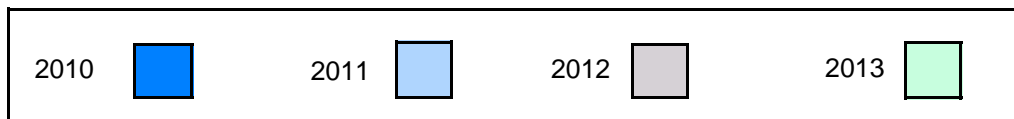

**Difference from Provincial Mean, 2010-13**

Multiple Choice

School data with 5 or fewer students withheld for reasons of confidentiality.

Reading

**Difference from Provincial Mean, 2010-13**

**Written Response: Percentage of students meeting/exceeding grade level expectations 2010-2013**

School data with 5 or fewer students withheld for reasons of confidentiality.

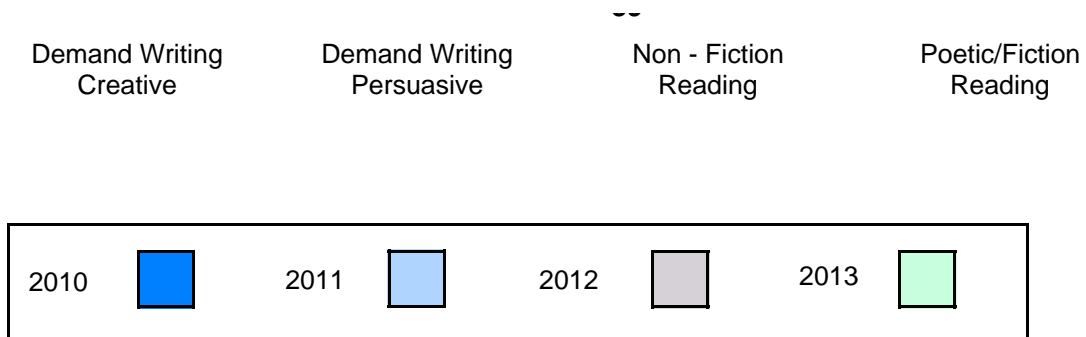

Number of Students : 9

**Multiple Choice**

**Reading**

School  
District  
Province

**Mark**

61.3  
71.4  
72.7

School  
vs  
District



School  
vs  
Province



**Closed Responses\***

**Demand Writing (Creative)**

School  
District  
Province

55.6  
66.5  
68.0



**Demand Writing (Persuasive)**

School  
District  
Province

62.5  
61.0  
60.8



**Non - Fiction Reading**

School  
District  
Province

50.0  
79.9  
80.1



**Fiction Reading**

School  
District  
Province

62.5  
62.1  
65.1



\* How to interpret the results for Closed Responses

On the Demand Writing (Creative) section, the students in Valmont Academy scored 55.6%. This means 55.6% of the students met or exceeded the cut score for this section.

4 Year CRT (Subtest) Mark Trend 2010-2013  
Multiple Choice

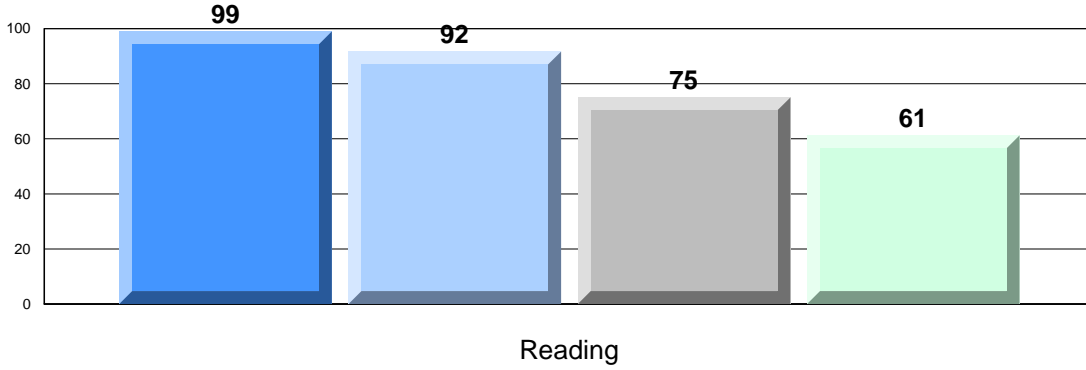

Written Response: Percentage of students meeting/exceeding grade level expectations 2010-2013

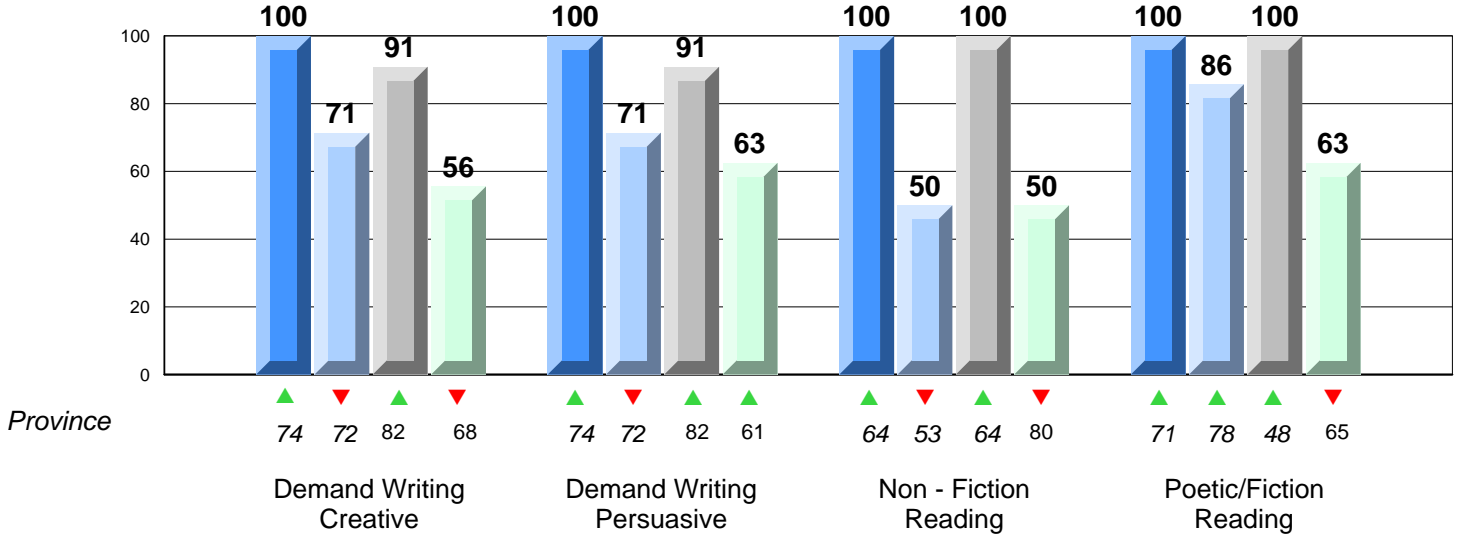

**Difference from Provincial Mean, 2010-13**

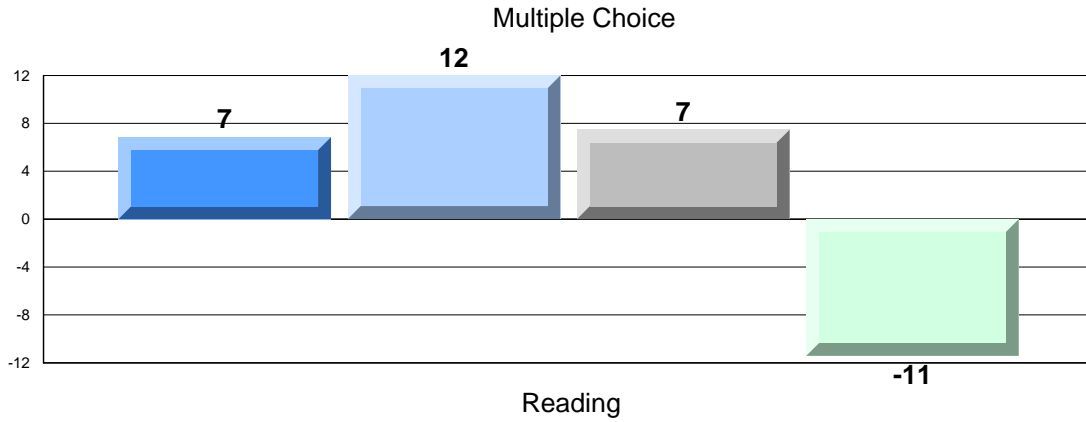

**Difference from Provincial Mean, 2010-13**

**Written Response: Percentage of students meeting/exceeding grade level expectations 2010-2013**

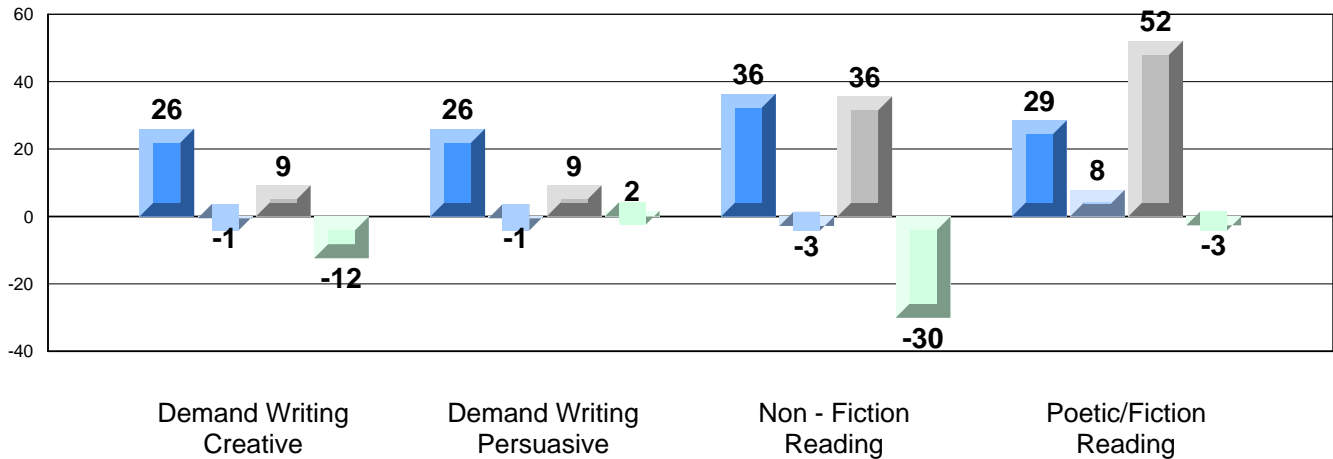



Number of Students : 13

**Multiple Choice**

**Reading**

School  
District  
Province

**Mark**

62.6  
71.4  
72.7

School  
vs  
District



School  
vs  
Province



**Closed Responses\***

**Demand Writing (Creative)**

School  
District  
Province

60.0  
66.5  
68.0



**Demand Writing (Persuasive)**

School  
District  
Province

100.0  
61.0  
60.8



**Non - Fiction Reading**

School  
District  
Province

63.6  
79.9  
80.1



**Fiction Reading**

School  
District  
Province

38.5  
62.1  
65.1



\* How to interpret the results for Closed Responses

On the Demand Writing (Creative) section, the students in Hillside Elementary scored 60.0%. This means 60.0% of the students met or exceeded the cut score for this section.

4 Year CRT (Subtest) Mark Trend 2010-2013  
Multiple Choice

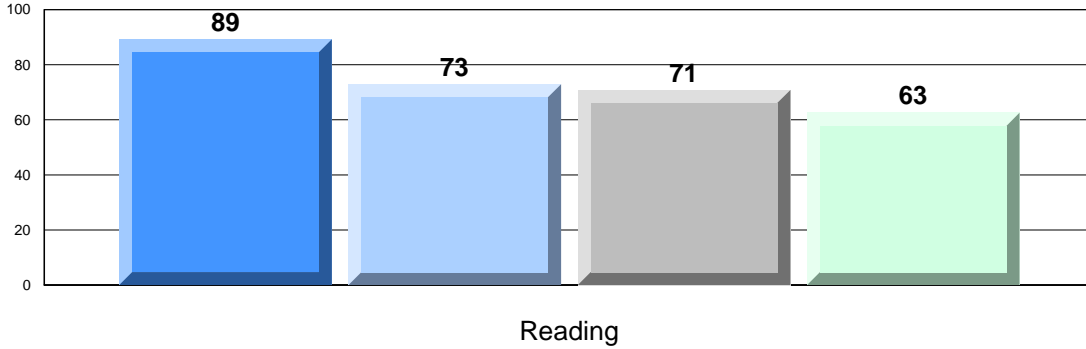

Written Response: Percentage of students meeting/exceeding grade level expectations 2010-2013

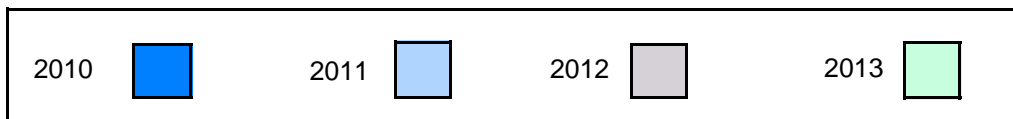
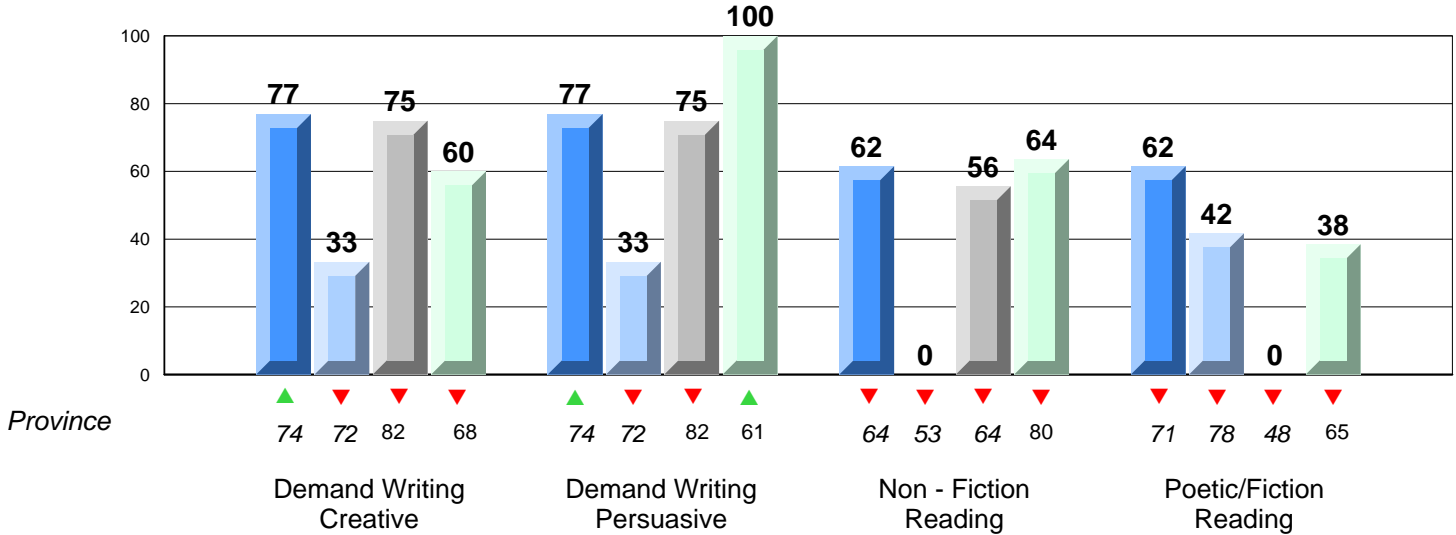

**Difference from Provincial Mean, 2010-13**

Multiple Choice

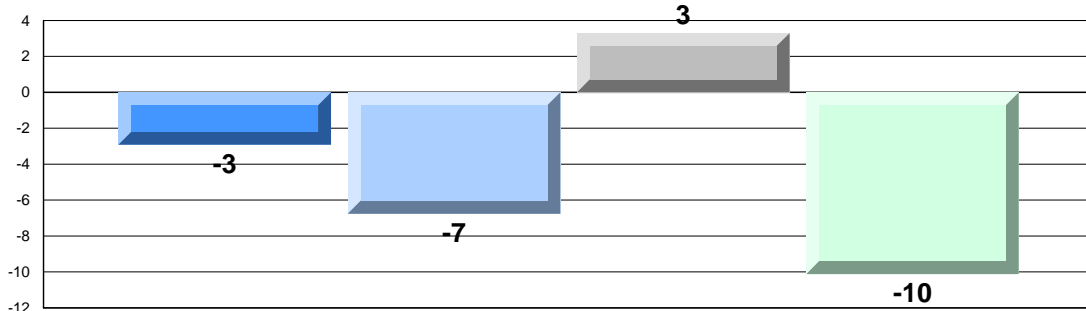

Reading

**Difference from Provincial Mean, 2010-13**

Written Response: Percentage of students meeting/exceeding grade level expectations 2010-2013

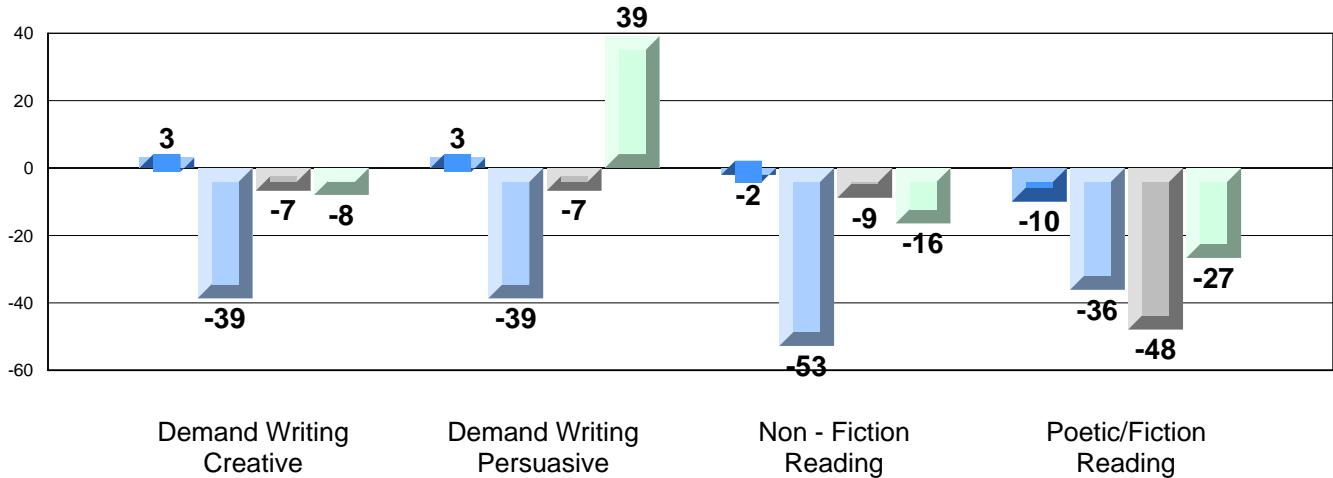

Number of Students : 3

**Multiple Choice**

**Reading**

School  
District  
Province

Mark	School vs District	School vs Province
School data with 5 or fewer students withheld for reasons of confidentiality.	▼	▼

**Closed Responses\***

**Demand Writing (Creative)**

School  
District  
Province

**Demand Writing (Persuasive)**

School  
District  
Province

**Non - Fiction Reading**

School  
District  
Province

**Fiction Reading**

School  
District  
Province



\* How to interpret the results for Closed Responses

On the Demand Writing (Creative) section, the students in Leading Tickles Primary scored 66.7%. This means 66.7% of the students met or exceeded the cut score for this section.

**4 Year CRT (Subtest) Mark Trend 2010-2013**  
**Multiple Choice**

School data with 5 or fewer students withheld for reasons of confidentiality.

Reading

**Written Response: Percentage of students meeting/exceeding grade level expectations 2010-2013**

School data with 5 or fewer students withheld for reasons of confidentiality.

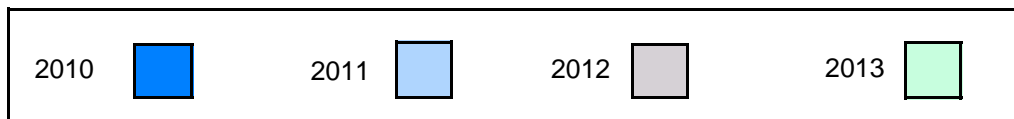
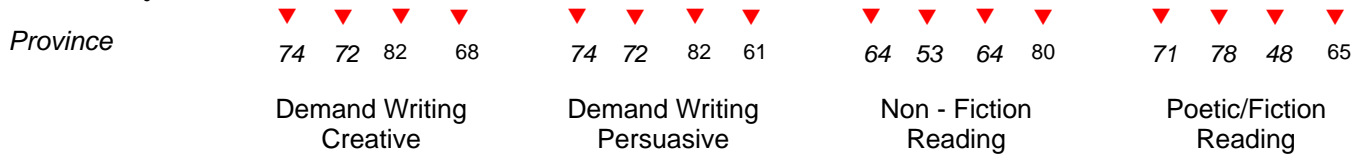

**Difference from Provincial Mean, 2010-13**

Multiple Choice

School data with 5 or fewer students withheld for reasons of confidentiality.

Reading

**Difference from Provincial Mean, 2010-13**

**Written Response: Percentage of students meeting/exceeding grade level expectations 2010-2013**

School data with 5 or fewer students withheld for reasons of confidentiality.

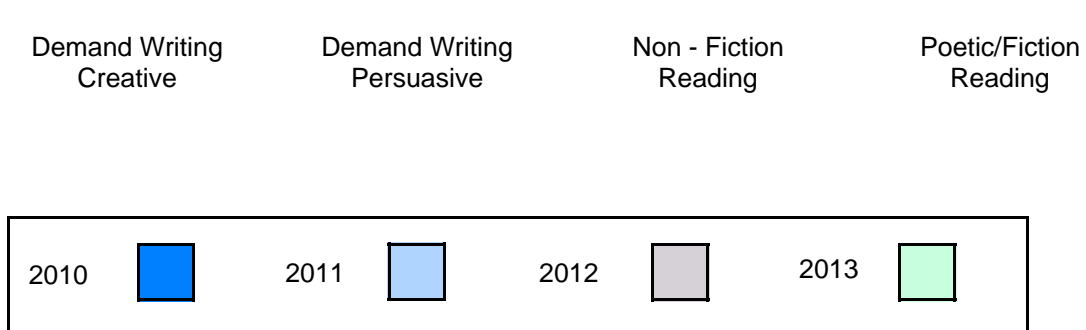

Number of Students : 1

**Multiple Choice**

**Reading**

School  
District  
Province

Mark	School vs District	School vs Province
School data with 5 or fewer students withheld for reasons of confidentiality.	▲	▲

**Closed Responses\***

**Demand Writing (Creative)**

School  
District  
Province

▲

▲

**Demand Writing (Persuasive)**

School  
District  
Province

▲

▲

**Non - Fiction Reading**

School  
District  
Province

▲

▲

**Fiction Reading**

School  
District  
Province

▲

▲

\* How to interpret the results for Closed Responses

On the Demand Writing (Creative) section, the students in St. Peter's AG scored 100.0%. This means 100.0% of the students met or exceeded the cut score for this section.

**4 Year CRT (Subtest) Mark Trend 2010-2013**  
**Multiple Choice**

School data with 5 or fewer students withheld for reasons of confidentiality.

Reading

**Written Response: Percentage of students meeting/exceeding grade level expectations 2010-2013**

School data with 5 or fewer students withheld for reasons of confidentiality.

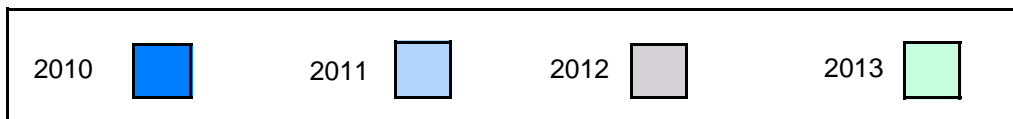
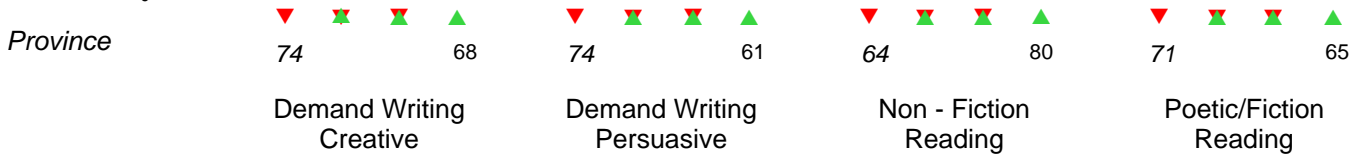



**Difference from Provincial Mean, 2010-13**

Multiple Choice

School data with 5 or fewer students withheld for reasons of confidentiality.

Reading

**Difference from Provincial Mean, 2010-13**

**Written Response: Percentage of students meeting/exceeding grade level expectations 2010-2013**

School data with 5 or fewer students withheld for reasons of confidentiality.

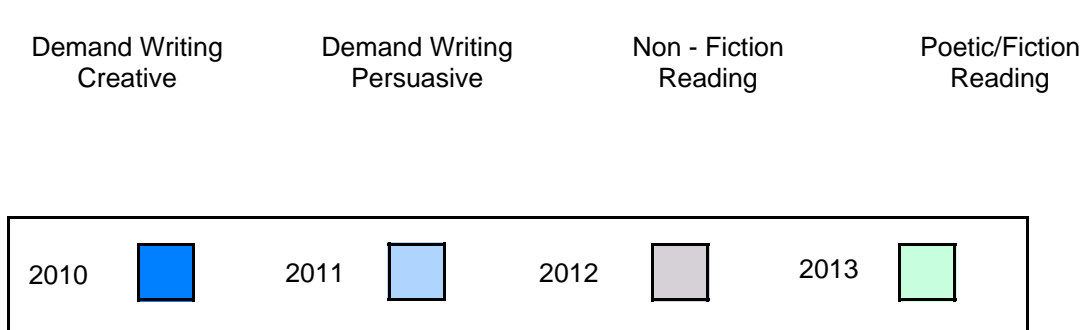

Number of Students : 9

**Multiple Choice**

**Reading**

School  
District  
Province

**Mark**

School  
vs  
District

School  
vs  
Province

82.2  
71.4  
72.7



**Closed Responses\***

**Demand Writing (Creative)**

School  
District  
Province

77.8  
66.5  
68.0



**Demand Writing (Persuasive)**

School  
District  
Province

55.6  
61.0  
60.8



**Non - Fiction Reading**

School  
District  
Province

100.0  
79.9  
80.1



**Fiction Reading**

School  
District  
Province

88.9  
62.1  
65.1



\* How to interpret the results for Closed Responses

On the Demand Writing (Creative) section, the students in MSB Regional Academy scored 77.8%. This means 77.8% of the students met or exceeded the cut score for this section.

4 Year CRT (Subtest) Mark Trend 2010-2013  
Multiple Choice

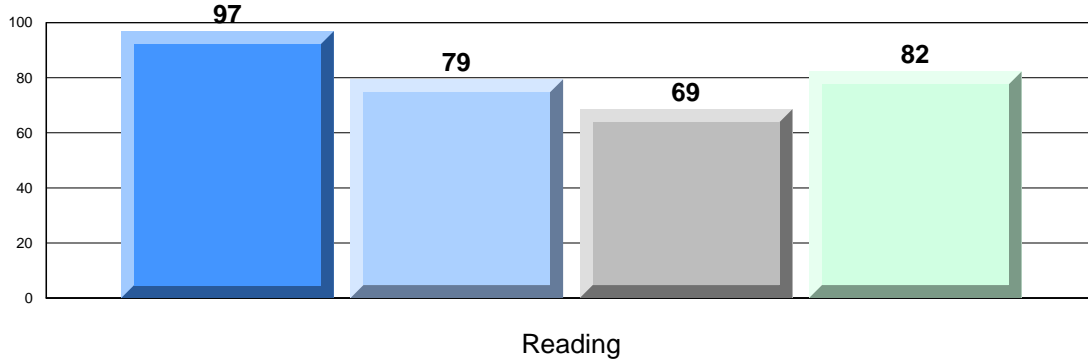

Written Response: Percentage of students meeting/exceeding grade level expectations 2010-2013

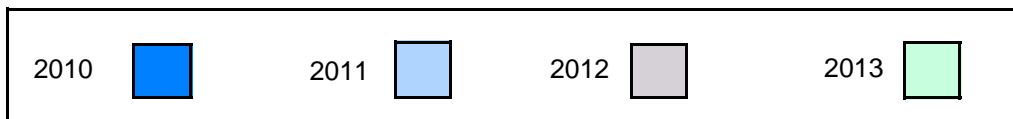
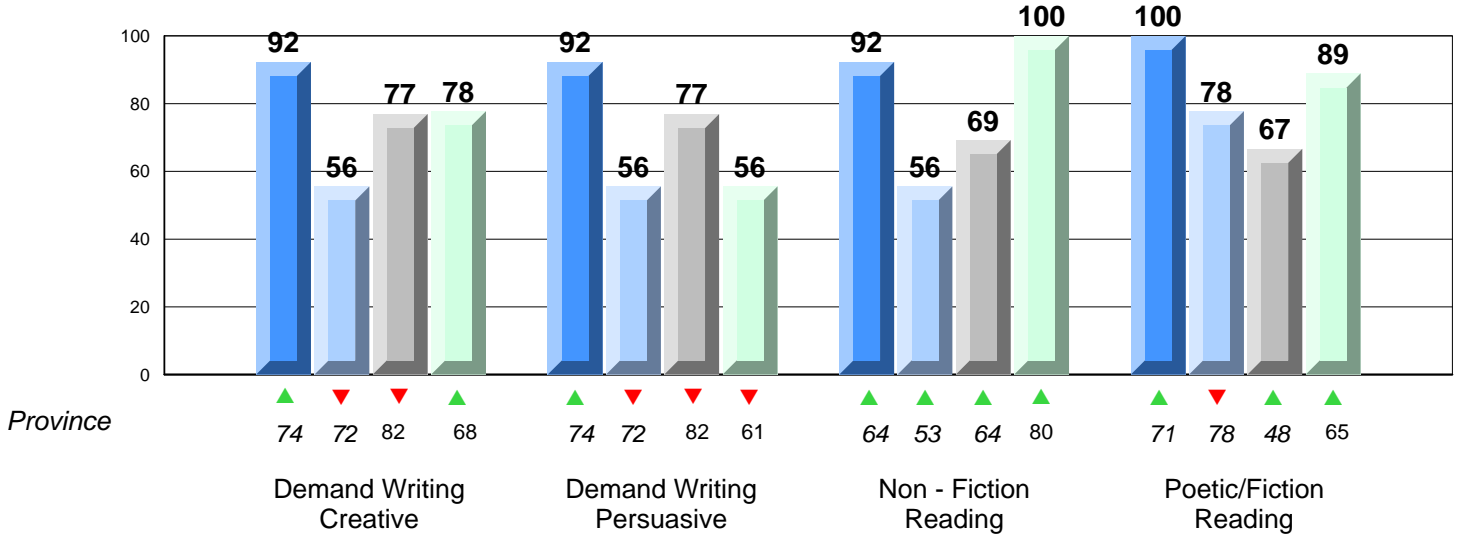

**Difference from Provincial Mean, 2010-13**

Multiple Choice

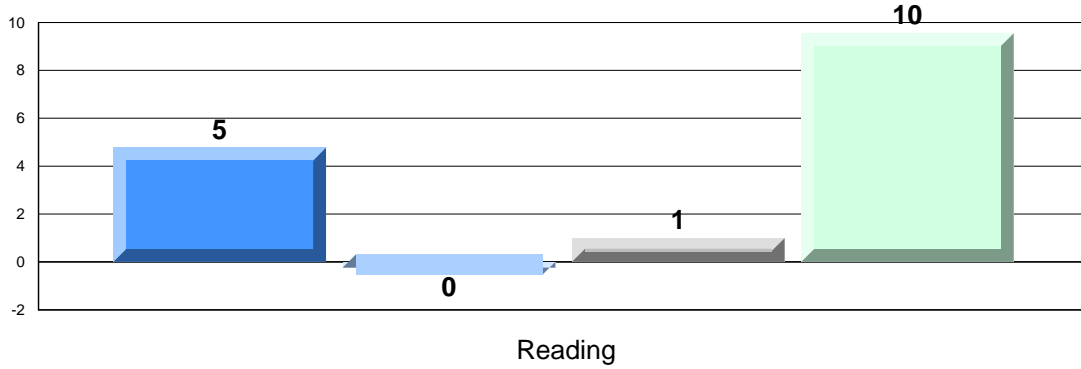

**Difference from Provincial Mean, 2010-13**

Written Response: Percentage of students meeting/exceeding grade level expectations 2010-2013

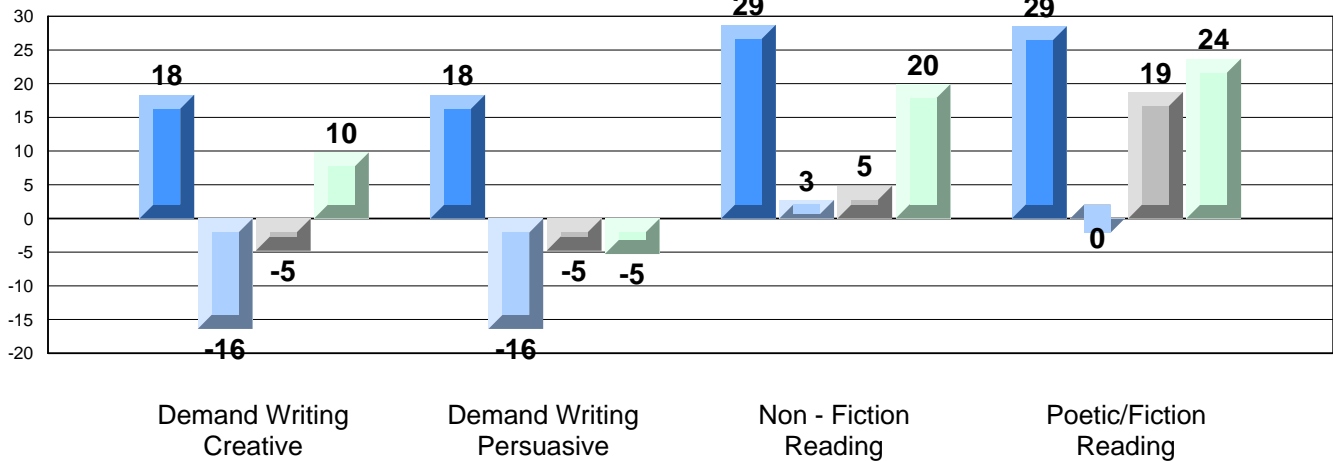

Number of Students : 1

**Multiple Choice**

**Reading**

School  
District  
Province

Mark	School vs District	School vs Province
School data with 5 or fewer students withheld for reasons of confidentiality.	▲	▲

**Closed Responses\***

**Demand Writing (Creative)**

School  
District  
Province

▲

▲

**Demand Writing (Persuasive)**

School  
District  
Province

▲

▲

**Non - Fiction Reading**

School  
District  
Province

▲

▲

**Fiction Reading**

School  
District  
Province

▲

▲

\* How to interpret the results for Closed Responses

On the Demand Writing (Creative) section, the students in Bayview Primary scored 100.0%. This means 100.0% of the students met or exceeded the cut score for this section.

**4 Year CRT (Subtest) Mark Trend 2010-2013**  
**Multiple Choice**

School data with 5 or fewer students withheld for reasons of confidentiality.

Reading

**Written Response: Percentage of students meeting/exceeding grade level expectations 2010-2013**

School data with 5 or fewer students withheld for reasons of confidentiality.

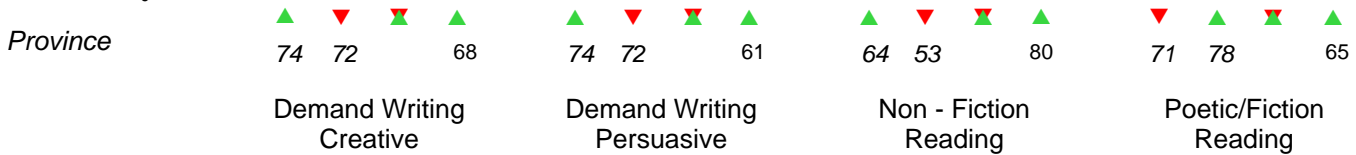

**Difference from Provincial Mean, 2010-13**

Multiple Choice

School data with 5 or fewer students withheld for reasons of confidentiality.

Reading

**Difference from Provincial Mean, 2010-13**

**Written Response: Percentage of students meeting/exceeding grade level expectations 2010-2013**

School data with 5 or fewer students withheld for reasons of confidentiality.

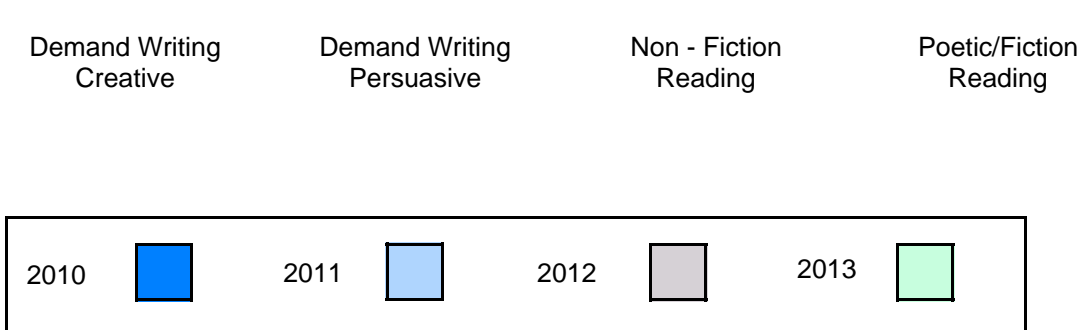

Number of Students : 3

**Multiple Choice**

**Reading**

School  
District  
Province

**Mark**

School  
vs  
District

School  
vs  
Province

School data  
with 5 or fewer  
students  
withheld for  
reasons of  
confidentiality.



**Closed Responses\***

**Demand Writing (Creative)**

School  
District  
Province



**Demand Writing (Persuasive)**

School  
District  
Province



**Non - Fiction Reading**

School  
District  
Province



**Fiction Reading**

School  
District  
Province



\* How to interpret the results for Closed Responses

On the Demand Writing (Creative) section, the students in Point Leamington Academy scored 0.0%. This means 0.0% of the students met or exceeded the cut score for this section.



**4 Year CRT (Subtest) Mark Trend 2010-2013**  
**Multiple Choice**

School data with 5 or fewer students withheld for reasons of confidentiality.

Reading

**Written Response: Percentage of students meeting/exceeding grade level expectations 2010-2013**

School data with 5 or fewer students withheld for reasons of confidentiality.

Province

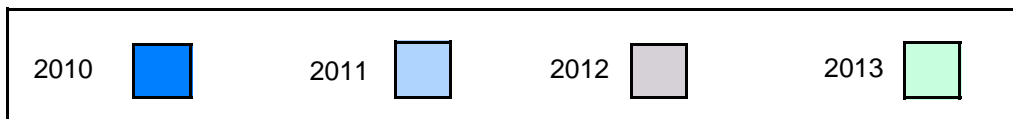

**Difference from Provincial Mean, 2010-13**

Multiple Choice

School data with 5 or fewer students withheld for reasons of confidentiality.

Reading

**Difference from Provincial Mean, 2010-13**

**Written Response: Percentage of students meeting/exceeding grade level expectations 2010-2013**

School data with 5 or fewer students withheld for reasons of confidentiality.

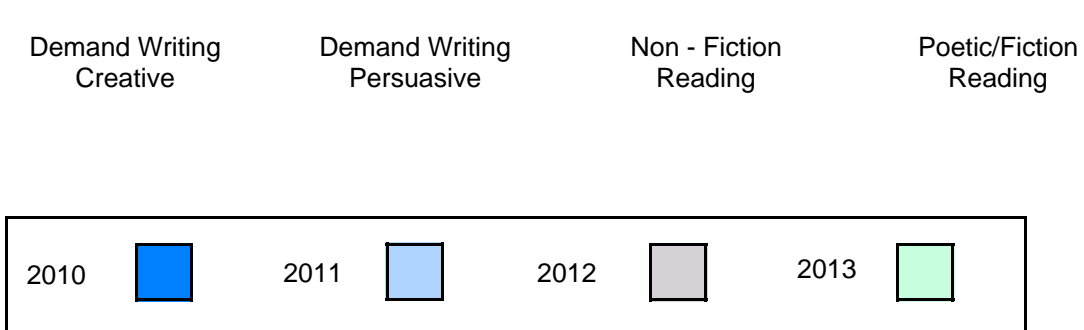

Number of Students : 2

**Multiple Choice**

Reading

School  
District  
Province

Mark	School vs District	School vs Province
School data with 5 or fewer students withheld for reasons of confidentiality.	▲	▲

**Closed Responses\***

Demand Writing (Creative)

School  
District  
Province

▼

▼

Demand Writing (Persuasive)

School  
District  
Province

▼

▼

Non - Fiction Reading

School  
District  
Province

▼

▼

Fiction Reading

School  
District  
Province

▼

▼

\* How to interpret the results for Closed Responses

On the Demand Writing (Creative) section, the students in St. Stephen's AG scored 50.0%. This means 50.0% of the students met or exceeded the cut score for this section.

**4 Year CRT (Subtest) Mark Trend 2010-2013**  
**Multiple Choice**

School data with 5 or fewer students withheld for reasons of confidentiality.

Reading

**Written Response: Percentage of students meeting/exceeding grade level expectations 2010-2013**

School data with 5 or fewer students withheld for reasons of confidentiality.

Province

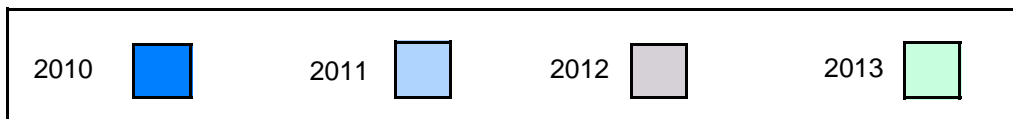

**Difference from Provincial Mean, 2010-13**

Multiple Choice

School data with 5 or fewer students withheld for reasons of confidentiality.

Reading

**Difference from Provincial Mean, 2010-13**

**Written Response: Percentage of students meeting/exceeding grade level expectations 2010-2013**

School data with 5 or fewer students withheld for reasons of confidentiality.

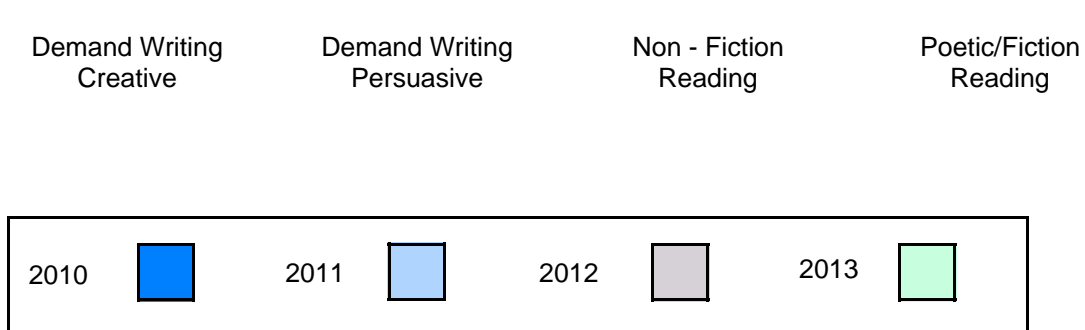

Number of Students : 8

**Multiple Choice**

**Reading**

School  
District  
Province

**Mark**

86.9  
71.4  
72.7

School  
vs  
District



School  
vs  
Province



**Closed Responses\***

**Demand Writing (Creative)**

School  
District  
Province

87.5  
66.5  
68.0



**Demand Writing (Persuasive)**

School  
District  
Province

100.0  
61.0  
60.8



**Non - Fiction Reading**

School  
District  
Province

100.0  
79.9  
80.1



**Fiction Reading**

School  
District  
Province

87.5  
62.1  
65.1



\* How to interpret the results for Closed Responses

On the Demand Writing (Creative) section, the students in Green Bay South Academy scored 87.5%. This means 87.5% of the students met or exceeded the cut score for this section.

4 Year CRT (Subtest) Mark Trend 2010-2013  
Multiple Choice

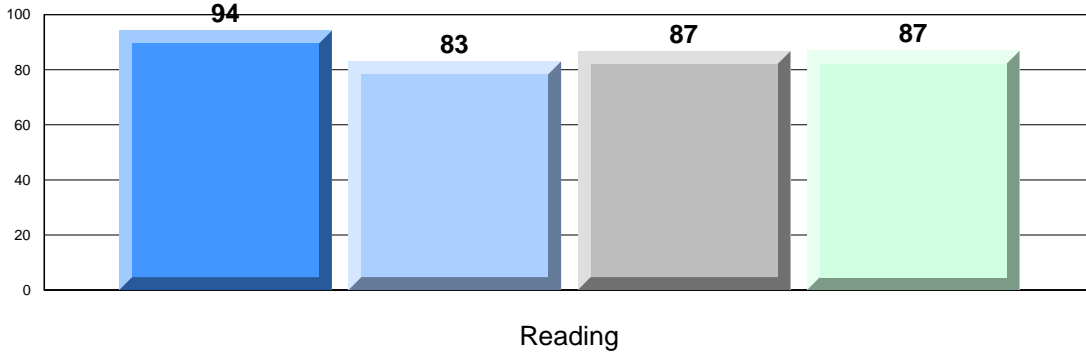

Written Response: Percentage of students meeting/exceeding grade level expectations 2010-2013

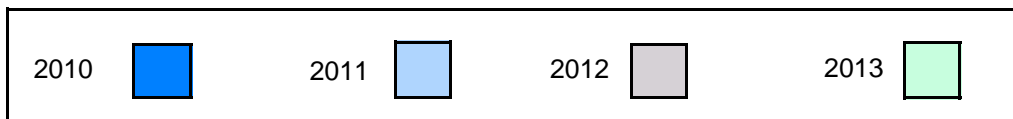
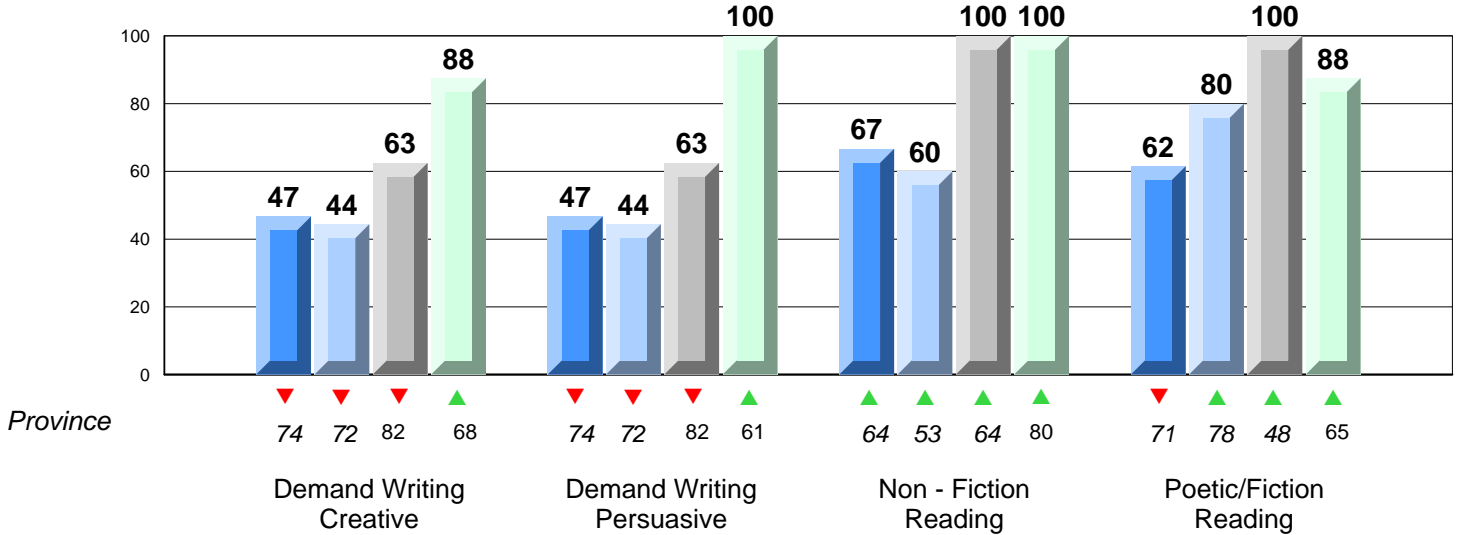

**Difference from Provincial Mean, 2010-13**

Multiple Choice

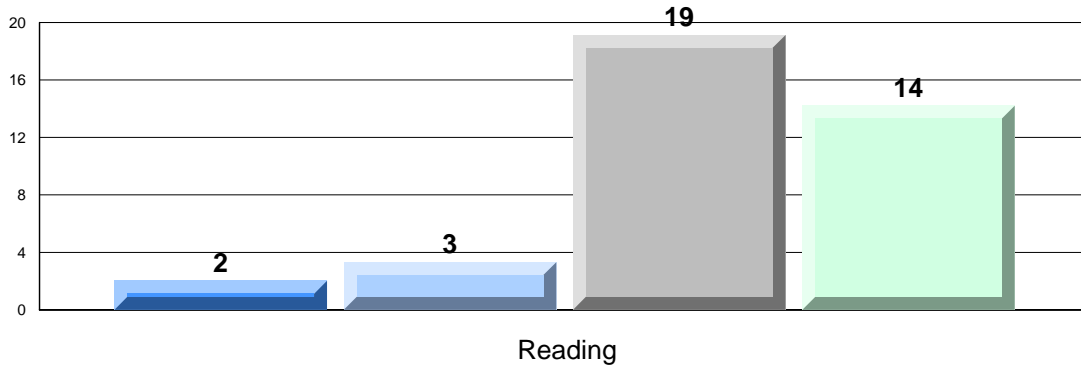

**Difference from Provincial Mean, 2010-13**

Written Response: Percentage of students meeting/exceeding grade level expectations 2010-2013

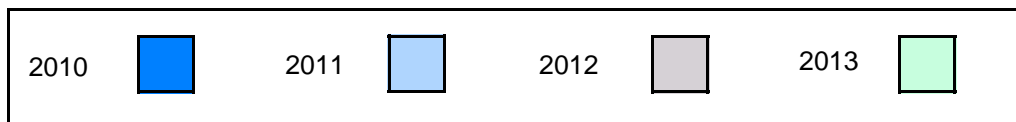
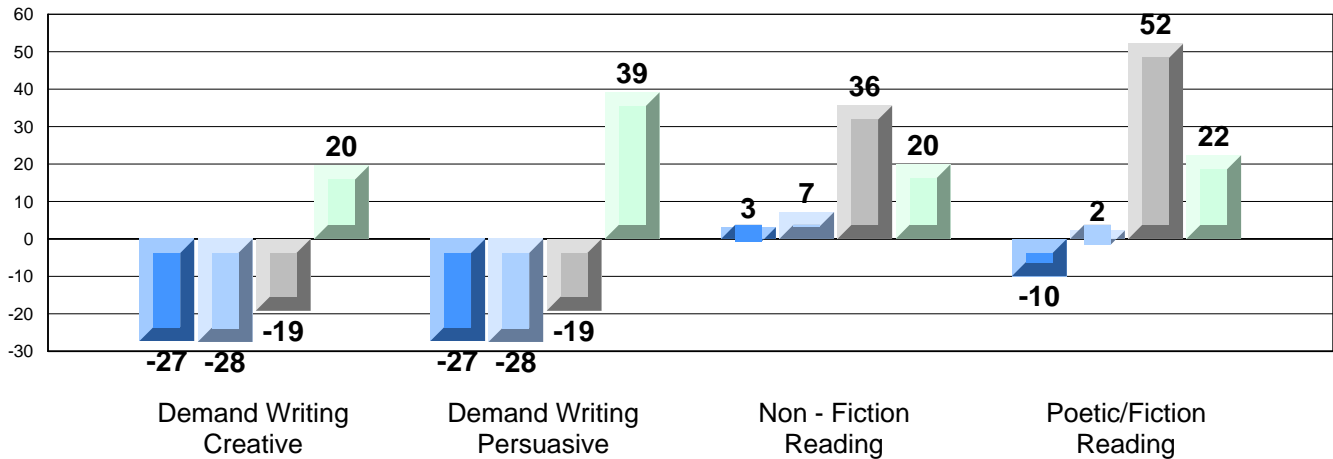



Number of Students : 13

**Multiple Choice**

**Reading**

School  
District  
Province

**Mark**

School  
vs  
District

School  
vs  
Province

72.7  
71.4  
72.7



**Closed Responses\***

**Demand Writing (Creative)**

School  
District  
Province

76.9  
66.5  
68.0



**Demand Writing (Persuasive)**

School  
District  
Province

92.3  
61.0  
60.8



**Non - Fiction Reading**

School  
District  
Province

84.6  
79.9  
80.1



**Fiction Reading**

School  
District  
Province

84.6  
62.1  
65.1



\* How to interpret the results for Closed Responses

On the Demand Writing (Creative) section, the students in Brian Peckford Primary scored 76.9%. This means 76.9% of the students met or exceeded the cut score for this section.

4 Year CRT (Subtest) Mark Trend 2010-2013  
Multiple Choice

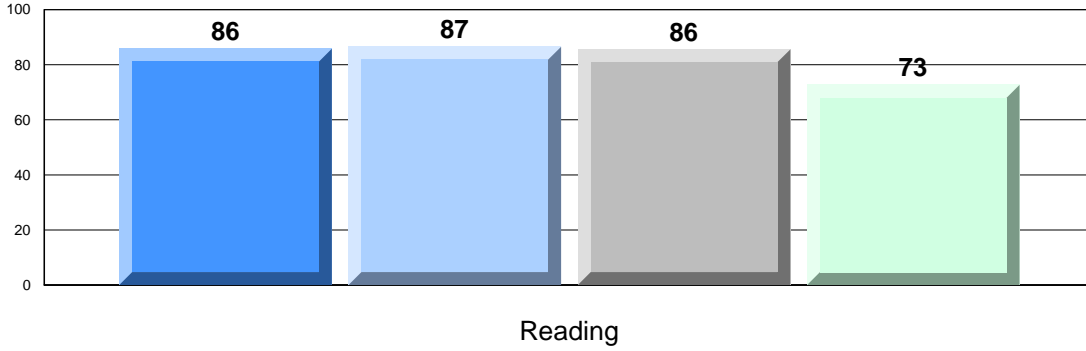

Written Response: Percentage of students meeting/exceeding grade level expectations 2010-2013

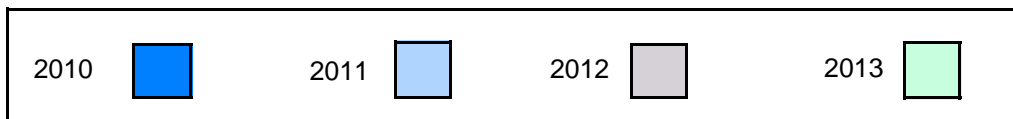
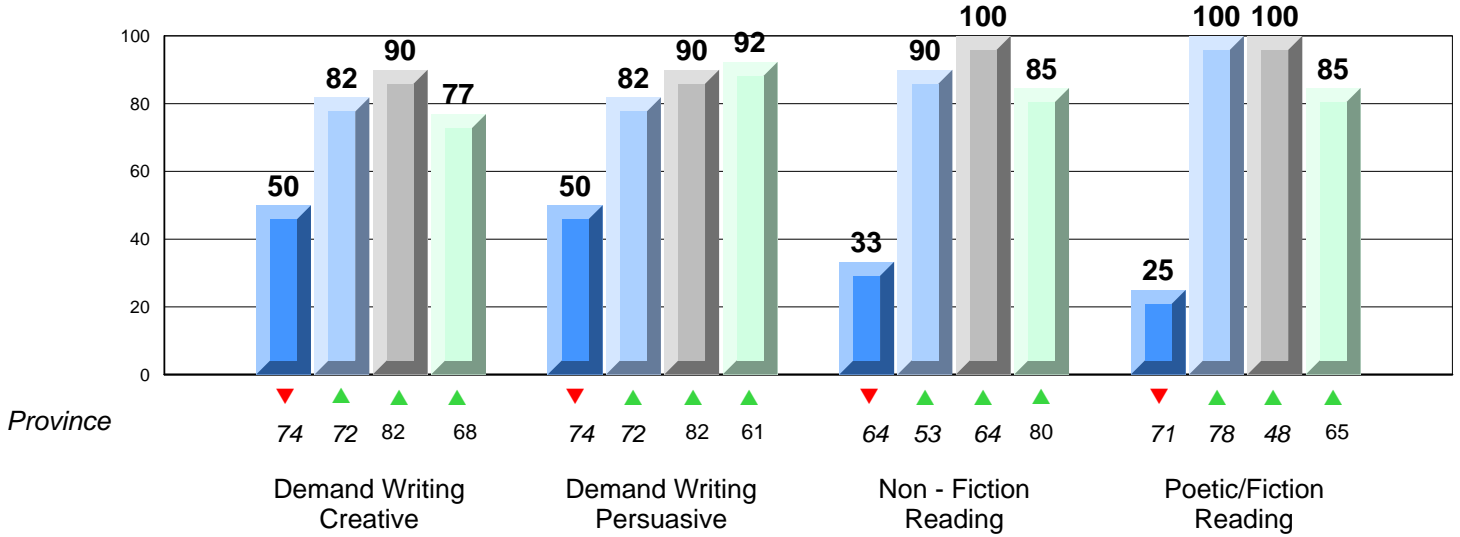

**Difference from Provincial Mean, 2010-13**

Multiple Choice

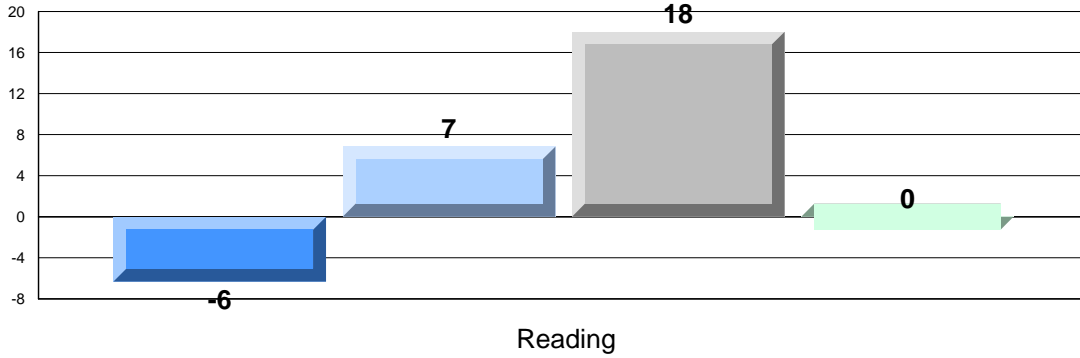

**Difference from Provincial Mean, 2010-13**

Written Response: Percentage of students meeting/exceeding grade level expectations 2010-2013

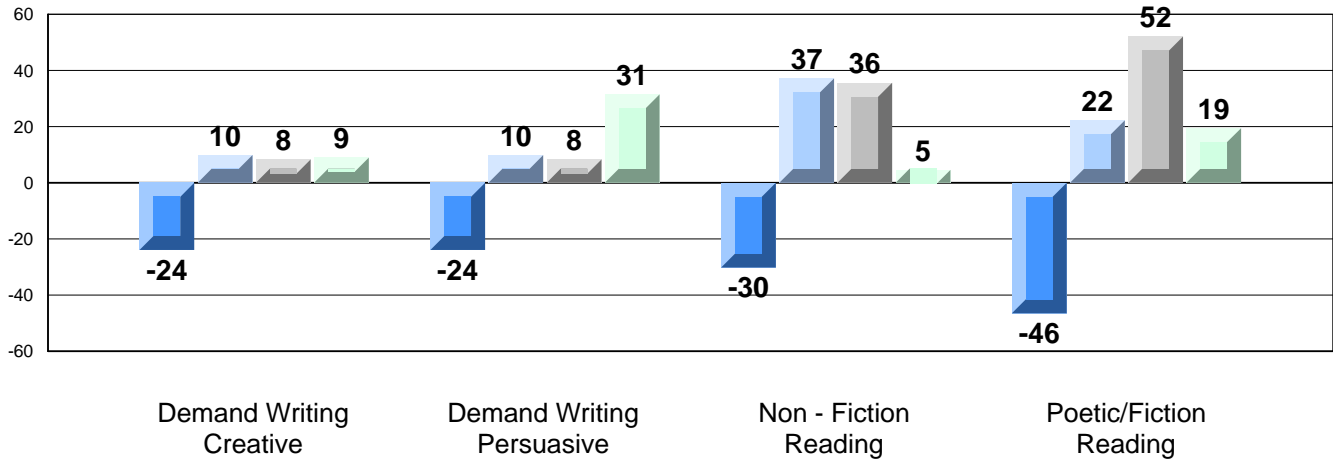

Number of Students : 11

**Multiple Choice**

**Reading**

School  
District  
Province

**Mark**

68.0  
71.4  
72.7

School  
vs  
District



School  
vs  
Province



**Closed Responses\***

**Demand Writing (Creative)**

School  
District  
Province

100.0  
66.5  
68.0



**Demand Writing (Persuasive)**

School  
District  
Province

63.6  
61.0  
60.8



**Non - Fiction Reading**

School  
District  
Province

90.9  
79.9  
80.1



**Fiction Reading**

School  
District  
Province

60.0  
62.1  
65.1



\* How to interpret the results for Closed Responses

On the Demand Writing (Creative) section, the students in Greenwood Academy scored 100.0%. This means 100.0% of the students met or exceeded the cut score for this section.

4 Year CRT (Subtest) Mark Trend 2010-2013  
Multiple Choice

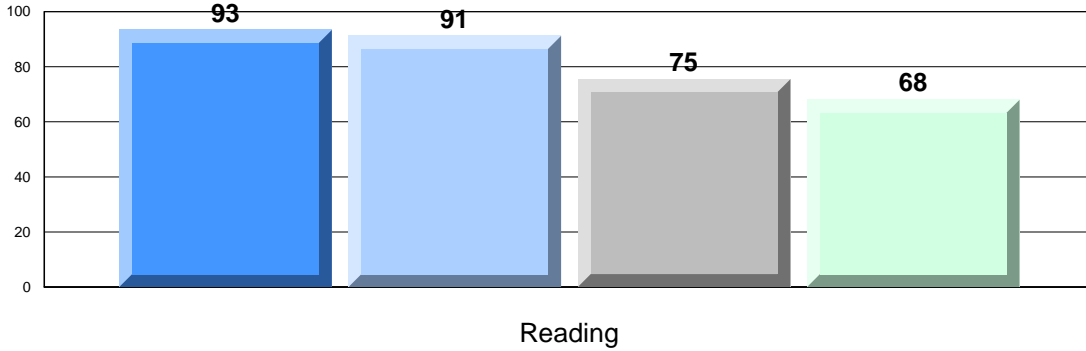

Written Response: Percentage of students meeting/exceeding grade level expectations 2010-2013

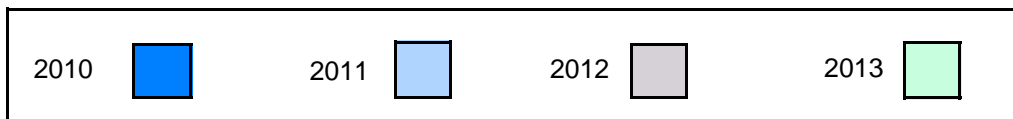
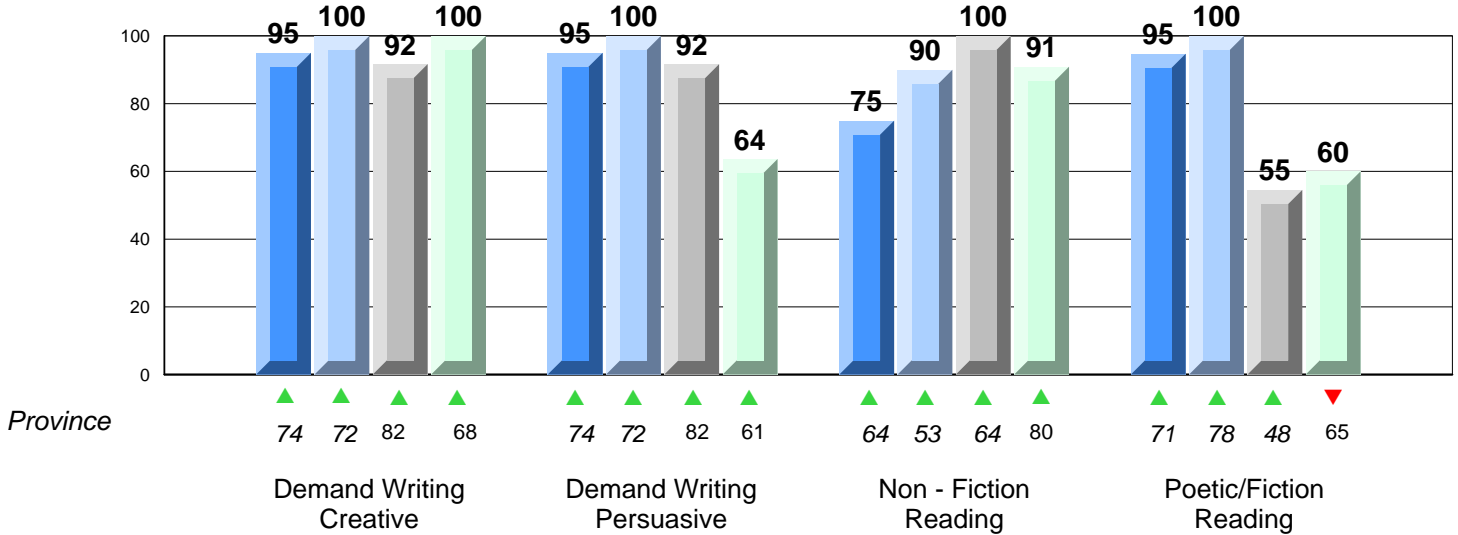

**Difference from Provincial Mean, 2010-13**

Multiple Choice

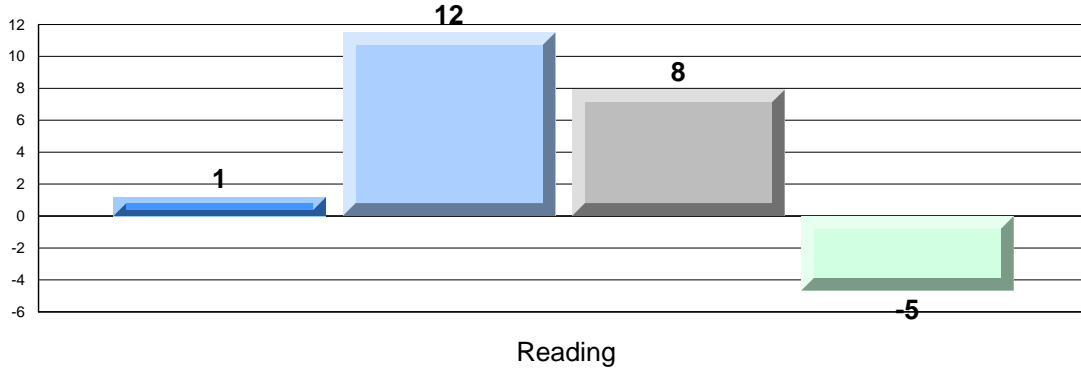

**Difference from Provincial Mean, 2010-13**

Written Response: Percentage of students meeting/exceeding grade level expectations 2010-2013

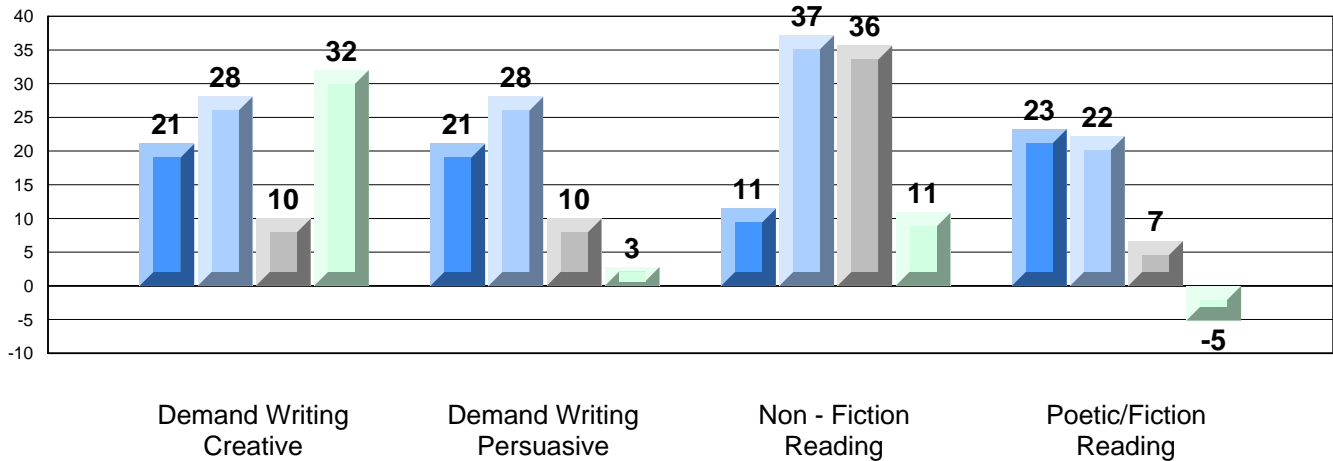

Number of Students : 25

**Multiple Choice**

**Reading**

School  
District  
Province

**Mark**

68.5  
71.4  
72.7

School  
vs  
District



School  
vs  
Province



**Closed Responses\***

**Demand Writing (Creative)**

School  
District  
Province

78.3  
66.5  
68.0



**Demand Writing (Persuasive)**

School  
District  
Province

54.5  
61.0  
60.8



**Non - Fiction Reading**

School  
District  
Province

75.0  
79.9  
80.1



**Fiction Reading**

School  
District  
Province

54.2  
62.1  
65.1



\* How to interpret the results for Closed Responses

On the Demand Writing (Creative) section, the students in Phoenix Academy scored 78.3%. This means 78.3% of the students met or exceeded the cut score for this section.

4 Year CRT (Subtest) Mark Trend 2010-2013  
Multiple Choice

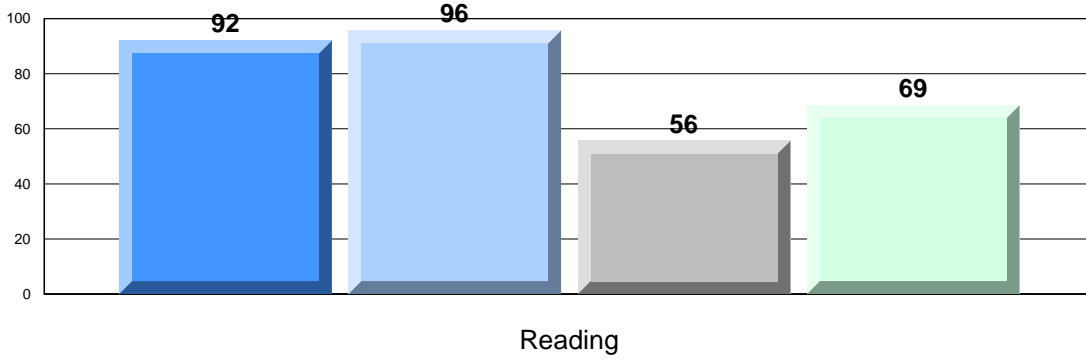

Written Response: Percentage of students meeting/exceeding grade level expectations 2010-2013

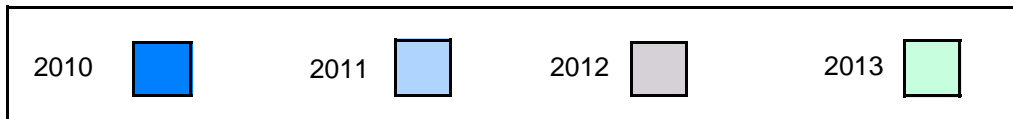
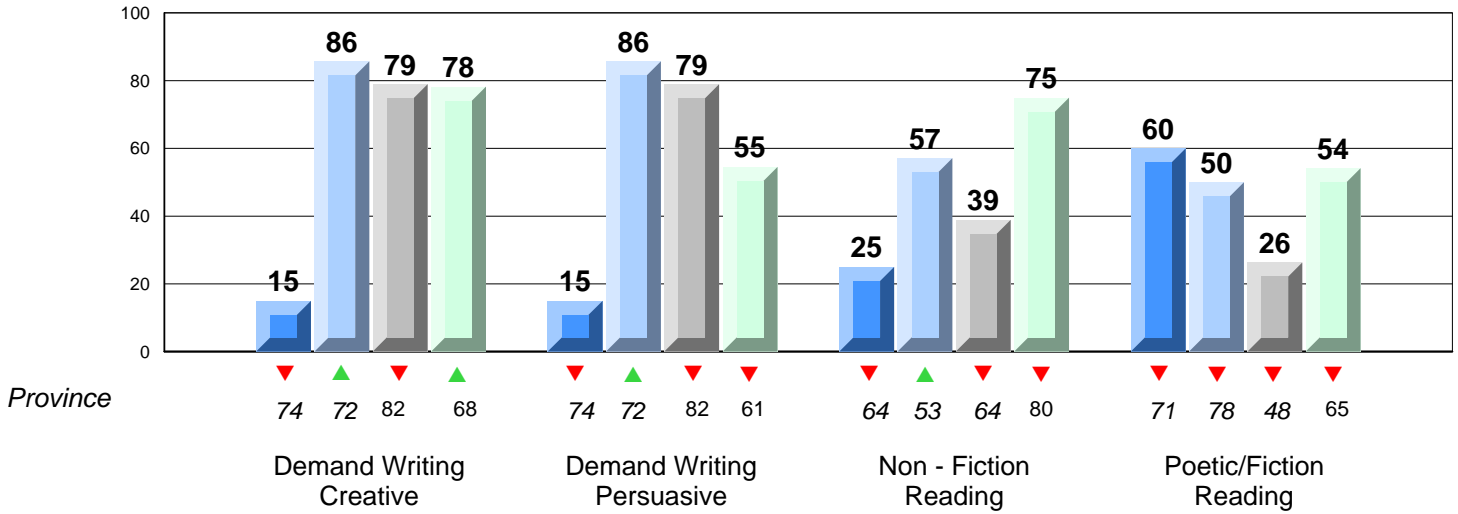



**Difference from Provincial Mean, 2010-13**

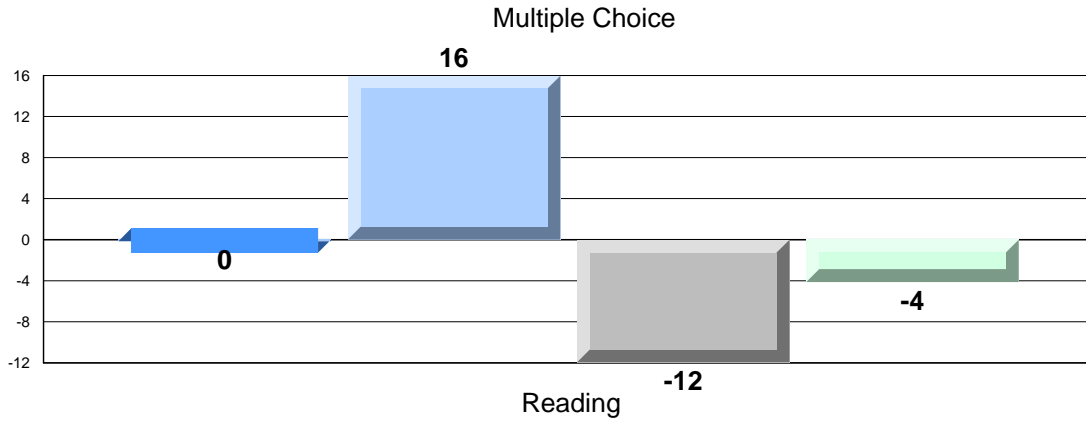

**Difference from Provincial Mean, 2010-13**

**Written Response: Percentage of students meeting/exceeding grade level expectations 2010-2013**

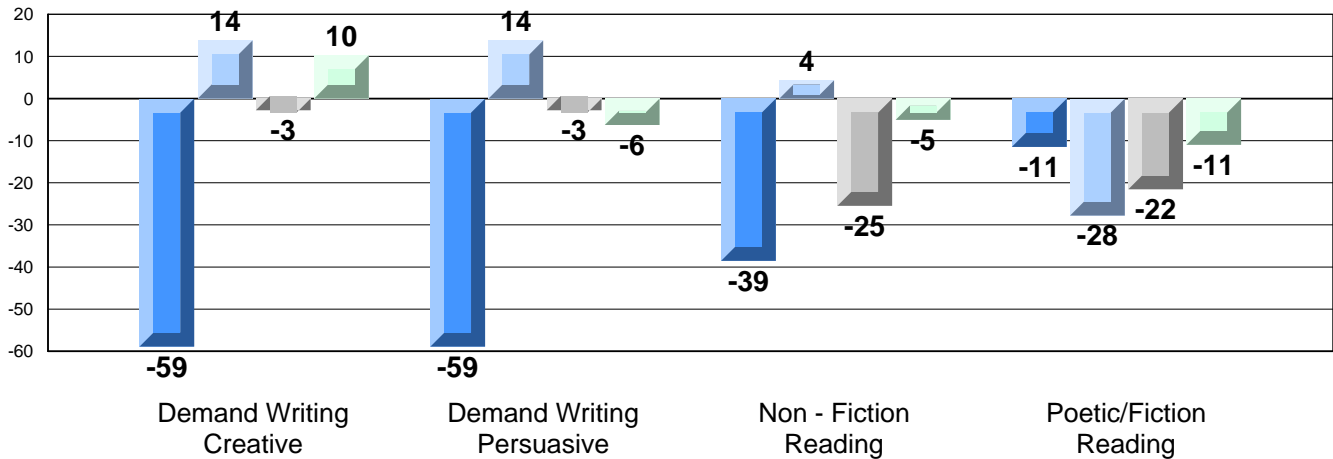

Number of Students : 16

**Multiple Choice**

**Reading**

School  
District  
Province

**Mark**

66.0  
71.4  
72.7

School  
vs  
District



School  
vs  
Province



**Closed Responses\***

**Demand Writing (Creative)**

School  
District  
Province

92.9  
66.5  
68.0



**Demand Writing (Persuasive)**

School  
District  
Province

62.5  
61.0  
60.8



**Non - Fiction Reading**

School  
District  
Province

50.0  
79.9  
80.1



**Fiction Reading**

School  
District  
Province

58.3  
62.1  
65.1



\* How to interpret the results for Closed Responses

On the Demand Writing (Creative) section, the students in Centreville Academy scored 92.9%. This means 92.9% of the students met or exceeded the cut score for this section.

4 Year CRT (Subtest) Mark Trend 2010-2013  
Multiple Choice

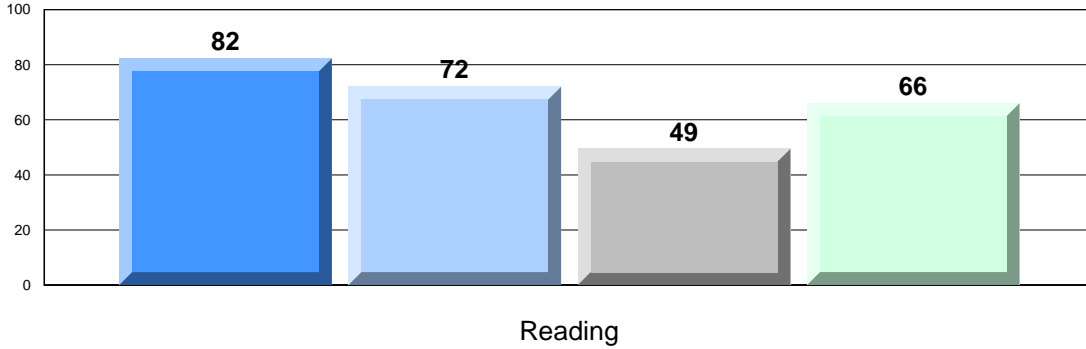

Written Response: Percentage of students meeting/exceeding grade level expectations 2010-2013

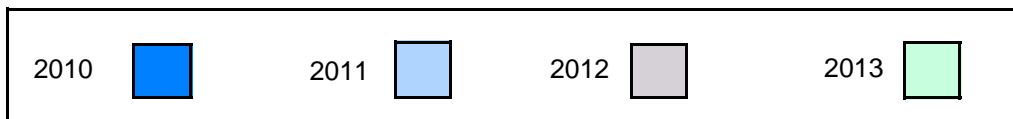
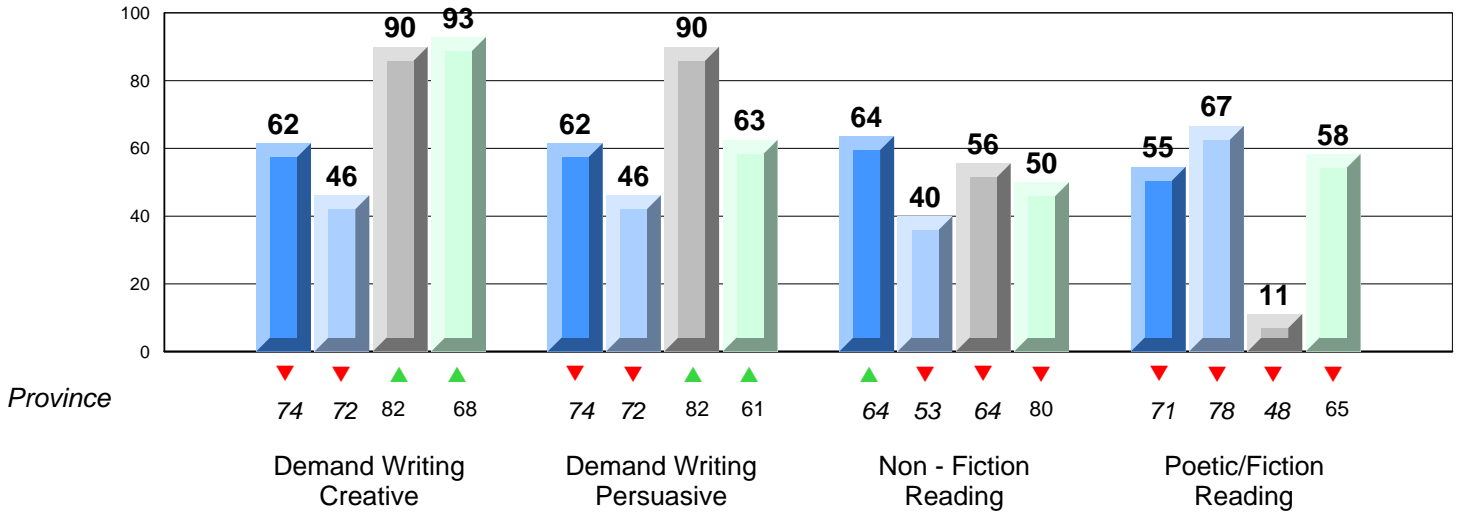

**Difference from Provincial Mean, 2010-13**

Multiple Choice

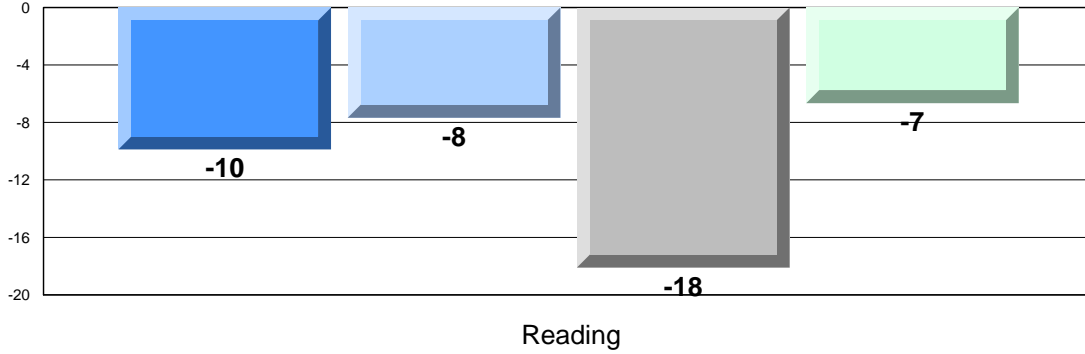

**Difference from Provincial Mean, 2010-13**

Written Response: Percentage of students meeting/exceeding grade level expectations 2010-2013

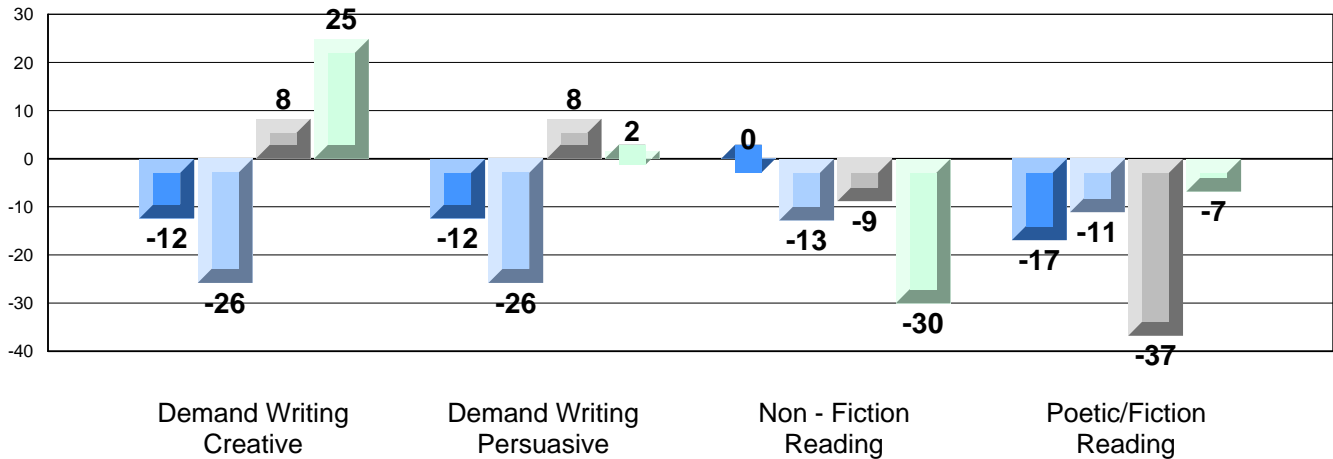

Number of Students : 1

**Multiple Choice**

**Reading**

School  
District  
Province

Mark	School vs District	School vs Province
School data with 5 or fewer students withheld for reasons of confidentiality.	▲	▲

**Closed Responses\***

**Demand Writing (Creative)**

School  
District  
Province

▼

▼

**Demand Writing (Persuasive)**

School  
District  
Province

▼

▼

**Non - Fiction Reading**

School  
District  
Province

▲

▲

**Fiction Reading**

School  
District  
Province

▲

▲

\* How to interpret the results for Closed Responses

On the Demand Writing (Creative) section, the students in A. R. Scammell Academy scored 0.0%. This means 0.0% of the students met or exceeded the cut score for this section.

**4 Year CRT (Subtest) Mark Trend 2010-2013**  
**Multiple Choice**

School data with 5 or fewer students withheld for reasons of confidentiality.

Reading

**Written Response: Percentage of students meeting/exceeding grade level expectations 2010-2013**

School data with 5 or fewer students withheld for reasons of confidentiality.

Province

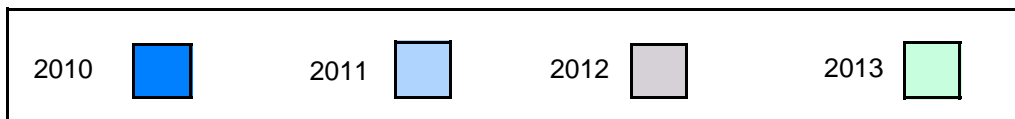
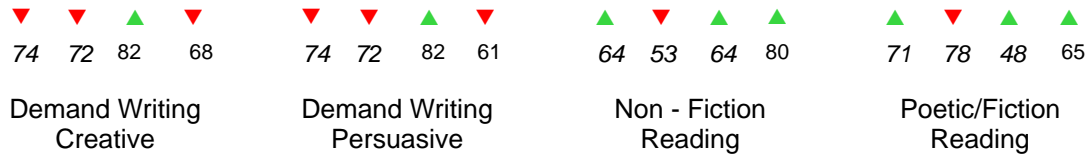

**Difference from Provincial Mean, 2010-13**

Multiple Choice

School data with 5 or fewer students withheld for reasons of confidentiality.

Reading

**Difference from Provincial Mean, 2010-13**

**Written Response: Percentage of students meeting/exceeding grade level expectations 2010-2013**

School data with 5 or fewer students withheld for reasons of confidentiality.

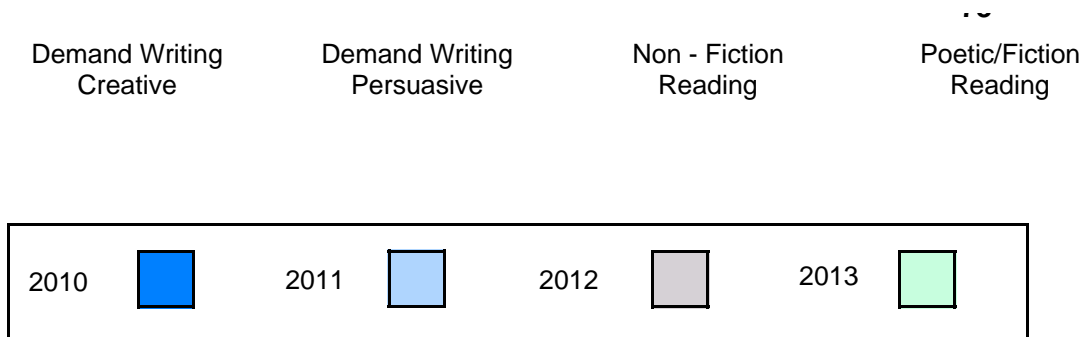

Number of Students : 5

**Multiple Choice**

**Reading**

School  
District  
Province

Mark	School vs District	School vs Province
School data with 5 or fewer students withheld for reasons of confidentiality.	▲	▲

**Closed Responses\***

**Demand Writing (Creative)**

School  
District  
Province

▲

▲

**Demand Writing (Persuasive)**

School  
District  
Province

▲

▲

**Non - Fiction Reading**

School  
District  
Province

▲

▲

**Fiction Reading**

School  
District  
Province

▲

▲

\* How to interpret the results for Closed Responses

On the Demand Writing (Creative) section, the students in Charlottetown Primary scored 100.0%. This means 100.0% of the students met or exceeded the cut score for this section.



**4 Year CRT (Subtest) Mark Trend 2010-2013**  
**Multiple Choice**

School data with 5 or fewer students withheld for reasons of confidentiality.

Reading

**Written Response: Percentage of students meeting/exceeding grade level expectations 2010-2013**

School data with 5 or fewer students withheld for reasons of confidentiality.

Province	2010	2011	2012	2013
Demand Writing Creative	74	72	82	68
Demand Writing Persuasive	74	72	82	61
Non - Fiction Reading	64	53	64	80
Poetic/Fiction Reading	71	78	48	65

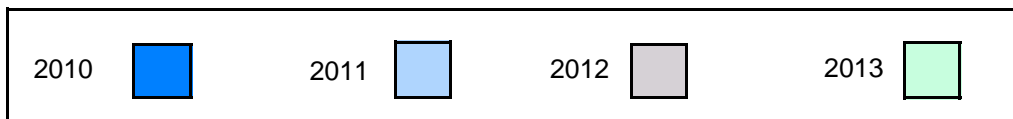

**Difference from Provincial Mean, 2010-13**

Multiple Choice

School data with 5 or fewer students withheld for reasons of confidentiality.

Reading

**Difference from Provincial Mean, 2010-13**

**Written Response: Percentage of students meeting/exceeding grade level expectations 2010-2013**

School data with 5 or fewer students withheld for reasons of confidentiality.

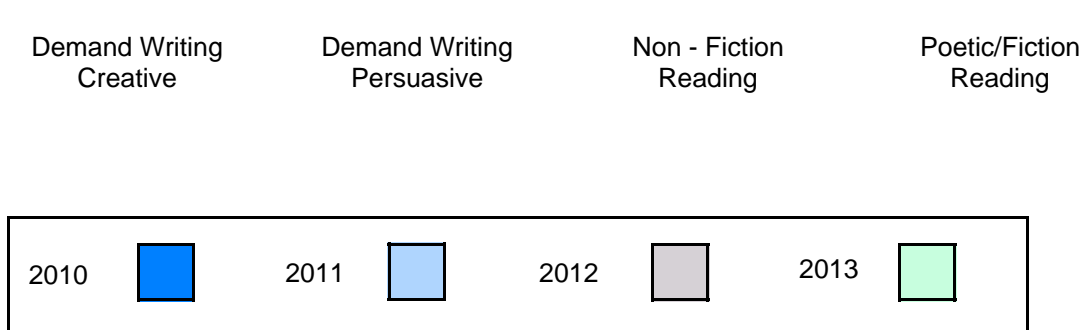

Number of Students : 17

**Multiple Choice**

**Reading**

School  
District  
Province

**Mark**

65.0  
71.4  
72.7

School  
vs  
District



School  
vs  
Province



**Closed Responses\***

**Demand Writing (Creative)**

School  
District  
Province

17.6  
66.5  
68.0



**Demand Writing (Persuasive)**

School  
District  
Province

18.8  
61.0  
60.8



**Non - Fiction Reading**

School  
District  
Province

56.3  
79.9  
80.1



**Fiction Reading**

School  
District  
Province

25.0  
62.1  
65.1



\* How to interpret the results for Closed Responses

On the Demand Writing (Creative) section, the students in William Mercer Academy scored 17.6%. This means 17.6% of the students met or exceeded the cut score for this section.

4 Year CRT (Subtest) Mark Trend 2010-2013  
Multiple Choice

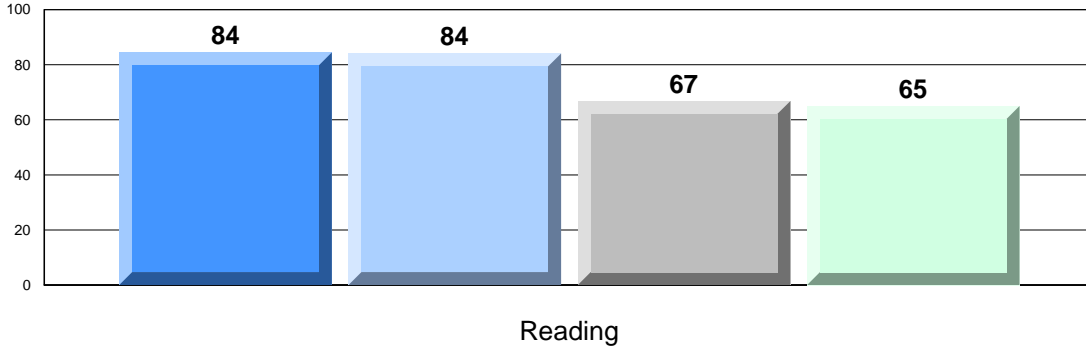

Written Response: Percentage of students meeting/exceeding grade level expectations 2010-2013

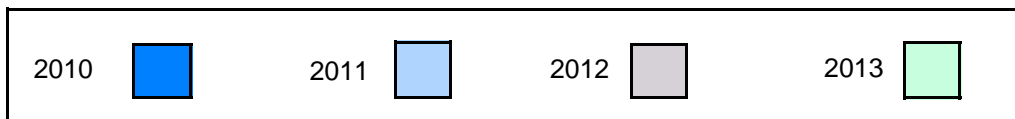
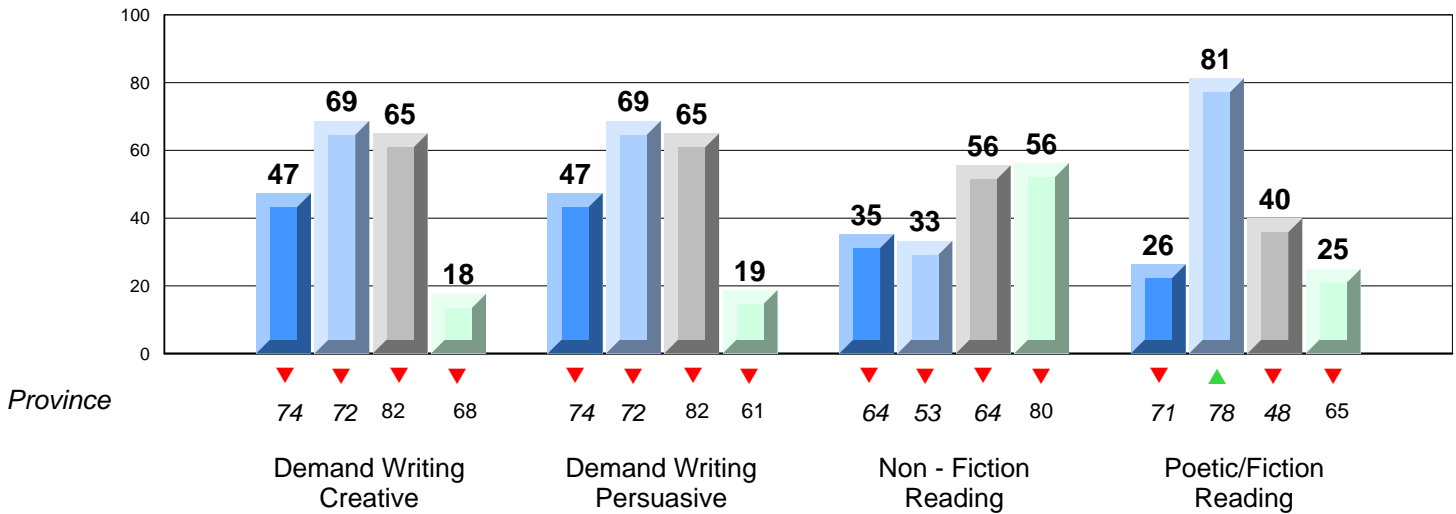

**Difference from Provincial Mean, 2010-13**

Multiple Choice

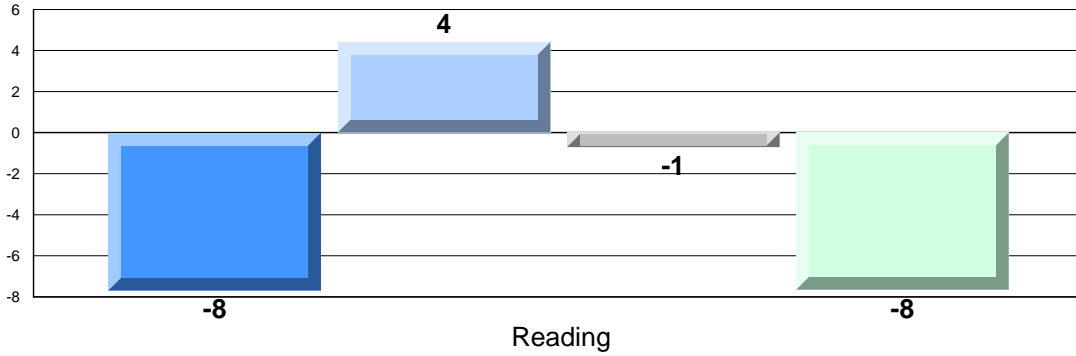

**Difference from Provincial Mean, 2010-13**

Written Response: Percentage of students meeting/exceeding grade level expectations 2010-2013

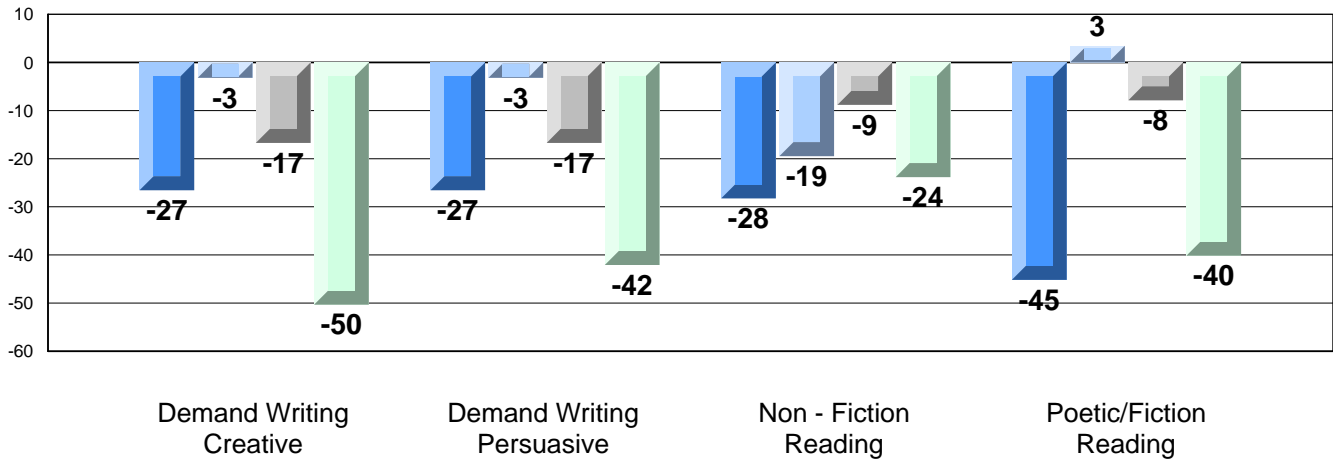

Number of Students : 2

**Multiple Choice**

**Reading**

School  
District  
Province

Mark	School vs District	School vs Province
School data with 5 or fewer students withheld for reasons of confidentiality.	▲	▲

**Closed Responses\***

**Demand Writing (Creative)**

School  
District  
Province

**Demand Writing (Persuasive)**

School  
District  
Province

**Non - Fiction Reading**

School  
District  
Province

**Fiction Reading**

School  
District  
Province

	▼	▼
	▼	▼
	▲	▲
	▲	▲

\* How to interpret the results for Closed Responses

On the Demand Writing (Creative) section, the students in Heritage Academy scored 50.0%. This means 50.0% of the students met or exceeded the cut score for this section.

**4 Year CRT (Subtest) Mark Trend 2010-2013**  
**Multiple Choice**

School data with 5 or fewer students withheld for reasons of confidentiality.

Reading

**Written Response: Percentage of students meeting/exceeding grade level expectations 2010-2013**

School data with 5 or fewer students withheld for reasons of confidentiality.

Province

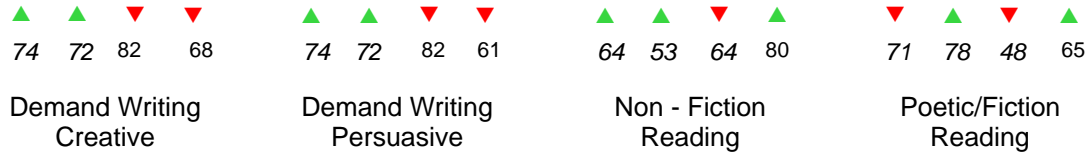

**Difference from Provincial Mean, 2010-13**

Multiple Choice

School data with 5 or fewer students withheld for reasons of confidentiality.

Reading

**Difference from Provincial Mean, 2010-13**

**Written Response: Percentage of students meeting/exceeding grade level expectations 2010-2013**

School data with 5 or fewer students withheld for reasons of confidentiality.

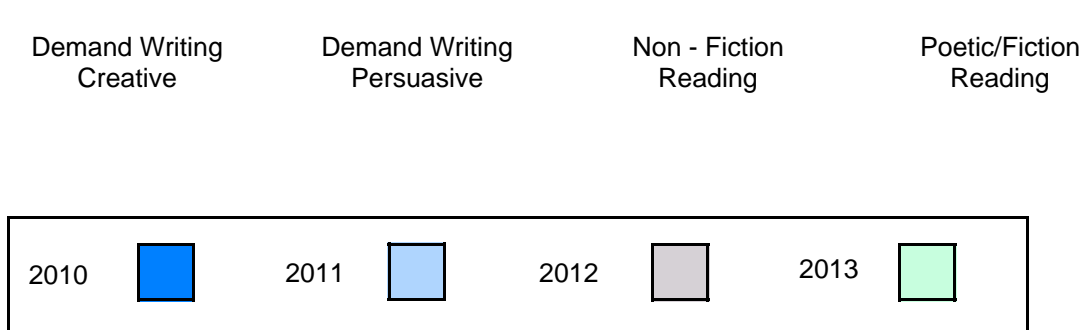



Number of Students : 2

**Multiple Choice**

**Reading**

School  
District  
Province

Mark	School vs District	School vs Province
School data with 5 or fewer students withheld for reasons of confidentiality.	▼	▼

**Closed Responses\***

**Demand Writing (Creative)**

School  
District  
Province

▲

▲

**Demand Writing (Persuasive)**

School  
District  
Province

▼

▼

**Non - Fiction Reading**

School  
District  
Province

▲

▲

**Fiction Reading**

School  
District  
Province

▼

▼

\* How to interpret the results for Closed Responses

On the Demand Writing (Creative) section, the students in Sandstone Academy scored 100.0%. This means 100.0% of the students met or exceeded the cut score for this section.

**4 Year CRT (Subtest) Mark Trend 2010-2013**  
**Multiple Choice**

School data with 5 or fewer students withheld for reasons of confidentiality.

Reading

**Written Response: Percentage of students meeting/exceeding grade level expectations 2010-2013**

School data with 5 or fewer students withheld for reasons of confidentiality.

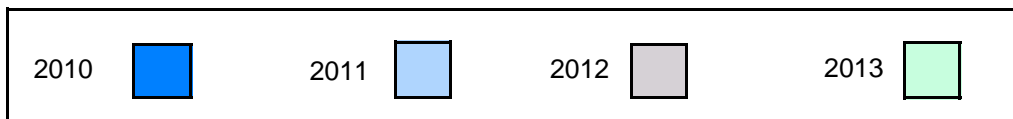
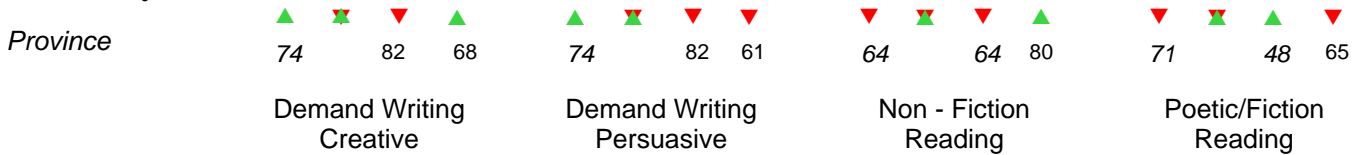

**Difference from Provincial Mean, 2010-13**

Multiple Choice

School data with 5 or fewer students withheld for reasons of confidentiality.

Reading

**Difference from Provincial Mean, 2010-13**

**Written Response: Percentage of students meeting/exceeding grade level expectations 2010-2013**

School data with 5 or fewer students withheld for reasons of confidentiality.

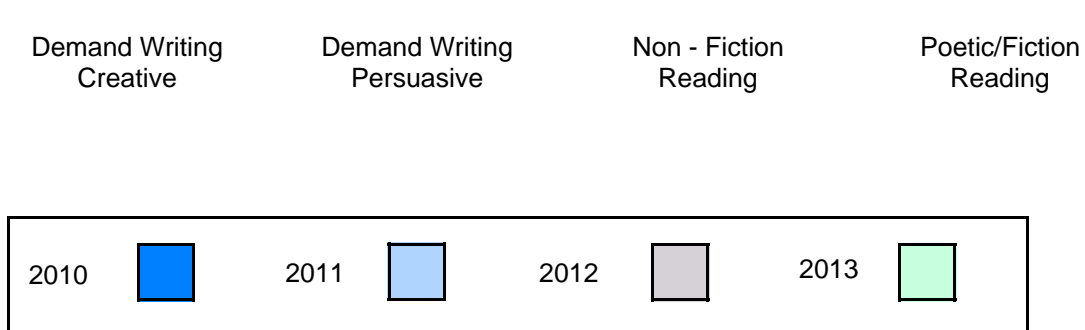

Number of Students : 46

**Multiple Choice**

**Reading**

School  
District  
Province

**Mark**

70.6  
71.4  
72.7

School  
vs  
District



School  
vs  
Province



**Closed Responses\***

**Demand Writing (Creative)**

School  
District  
Province

65.2  
66.5  
68.0



**Demand Writing (Persuasive)**

School  
District  
Province

54.5  
61.0  
60.8



**Non - Fiction Reading**

School  
District  
Province

79.5  
79.9  
80.1



**Fiction Reading**

School  
District  
Province

50.0  
62.1  
65.1



\* How to interpret the results for Closed Responses

On the Demand Writing (Creative) section, the students in Lewisporte Academy scored 65.2%. This means 65.2% of the students met or exceeded the cut score for this section.

4 Year CRT (Subtest) Mark Trend 2010-2013  
Multiple Choice

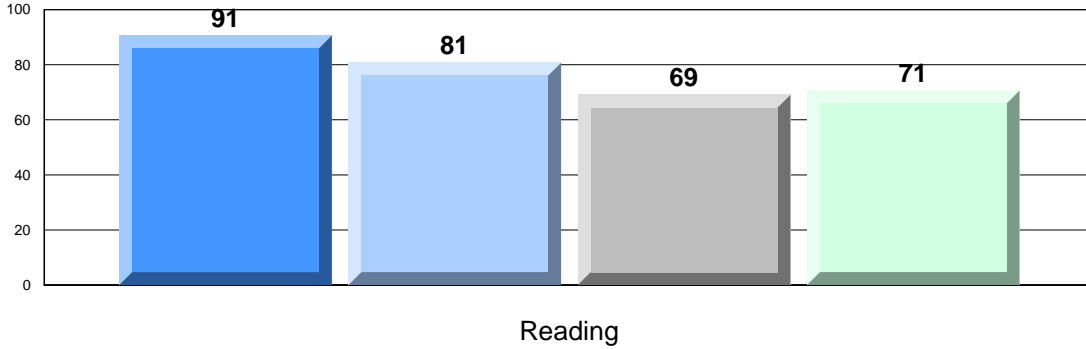

Written Response: Percentage of students meeting/exceeding grade level expectations 2010-2013

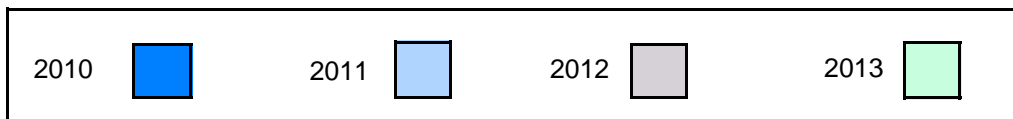
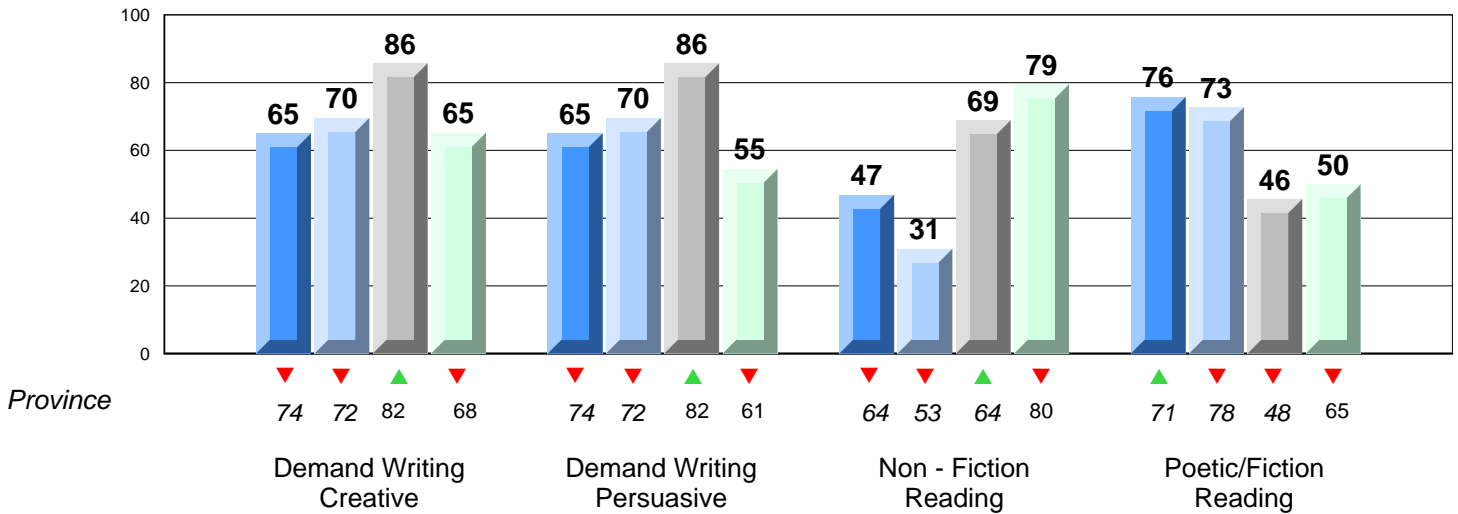

**Difference from Provincial Mean, 2010-13**

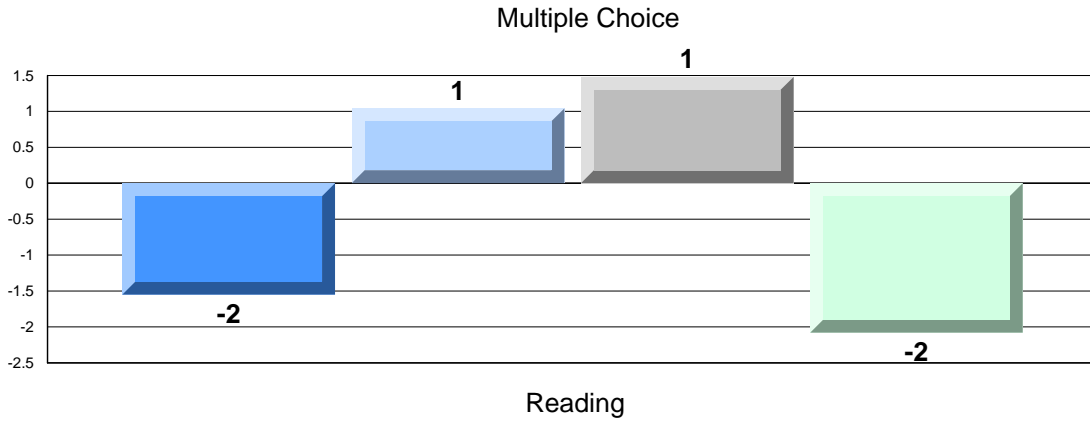

**Difference from Provincial Mean, 2010-13**

**Written Response: Percentage of students meeting/exceeding grade level expectations 2010-2013**

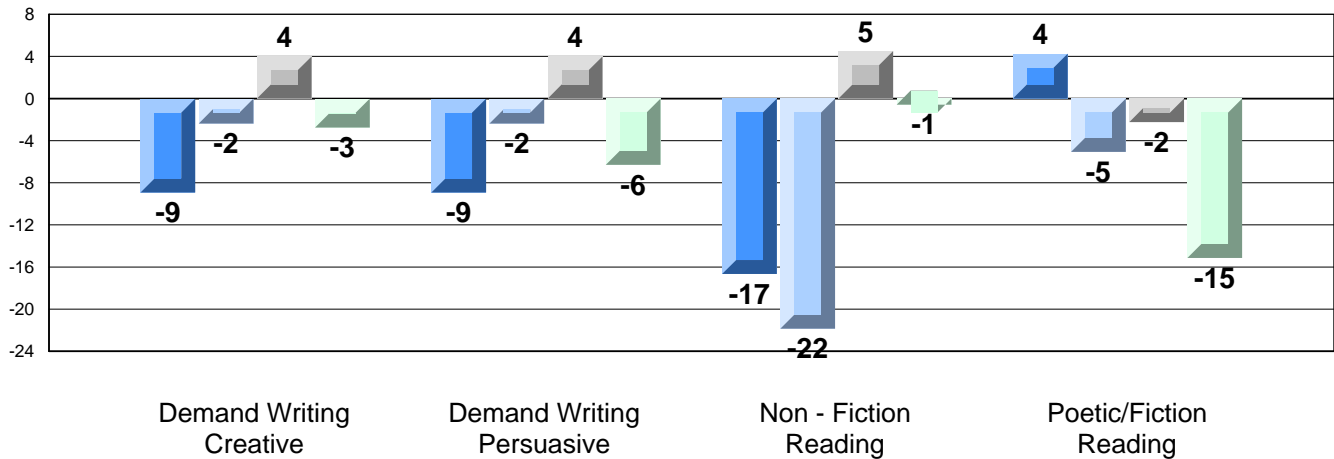

Number of Students : 8

**Multiple Choice**

**Reading**

School  
District  
Province

**Mark**

School  
vs  
District

School  
vs  
Province

84.4  
71.4  
72.7



**Closed Responses\***

**Demand Writing (Creative)**

School  
District  
Province

62.5  
66.5  
68.0



**Demand Writing (Persuasive)**

School  
District  
Province

75.0  
61.0  
60.8



**Non - Fiction Reading**

School  
District  
Province

75.0  
79.9  
80.1



**Fiction Reading**

School  
District  
Province

87.5  
62.1  
65.1



\* How to interpret the results for Closed Responses

On the Demand Writing (Creative) section, the students in Lumsden Academy scored 62.5%. This means 62.5% of the students met or exceeded the cut score for this section.

4 Year CRT (Subtest) Mark Trend 2010-2013  
Multiple Choice

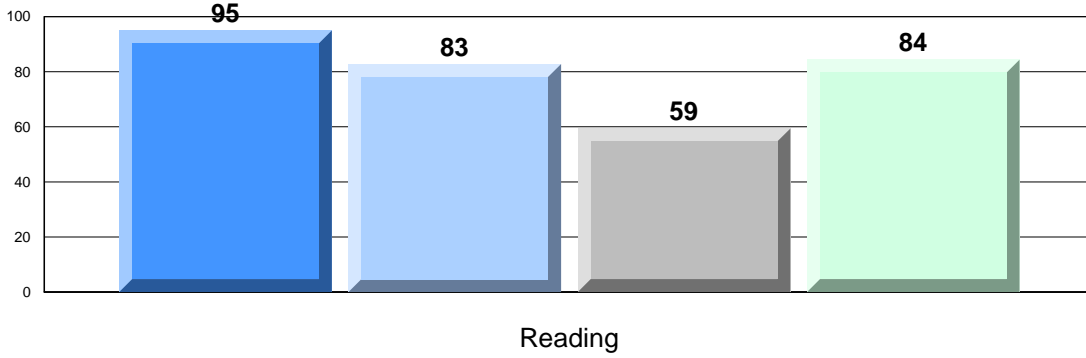

Written Response: Percentage of students meeting/exceeding grade level expectations 2010-2013

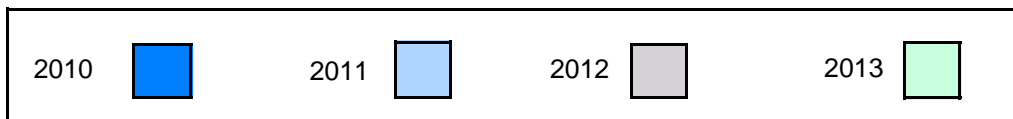
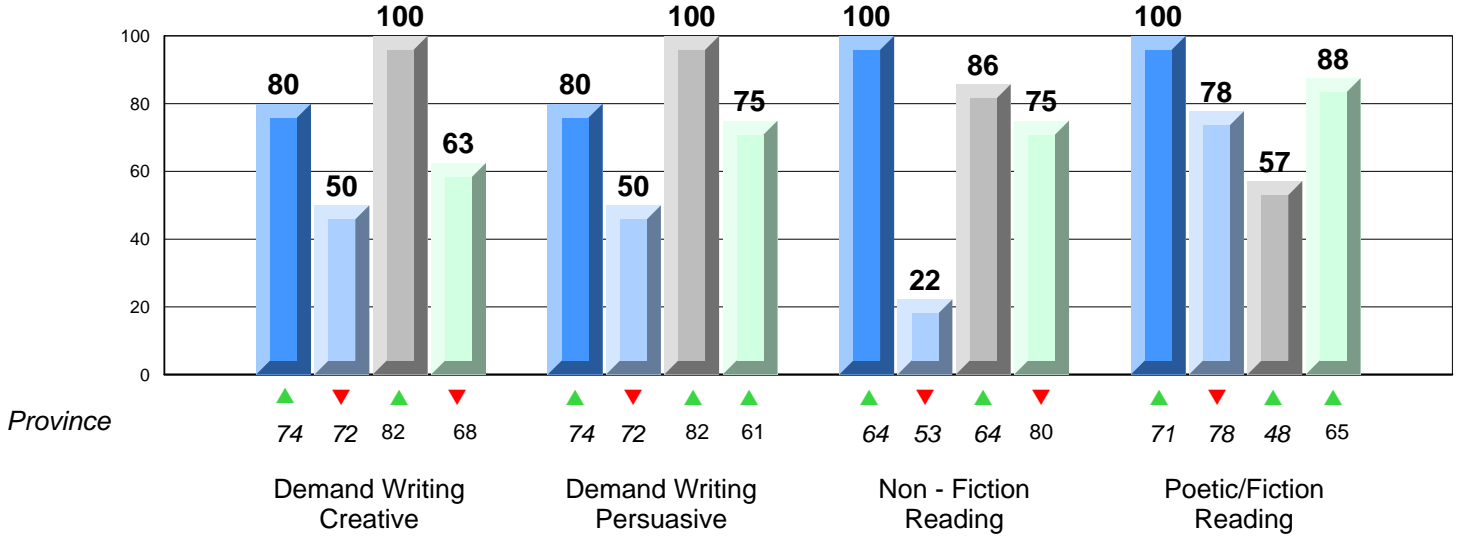



**Difference from Provincial Mean, 2010-13**

Multiple Choice

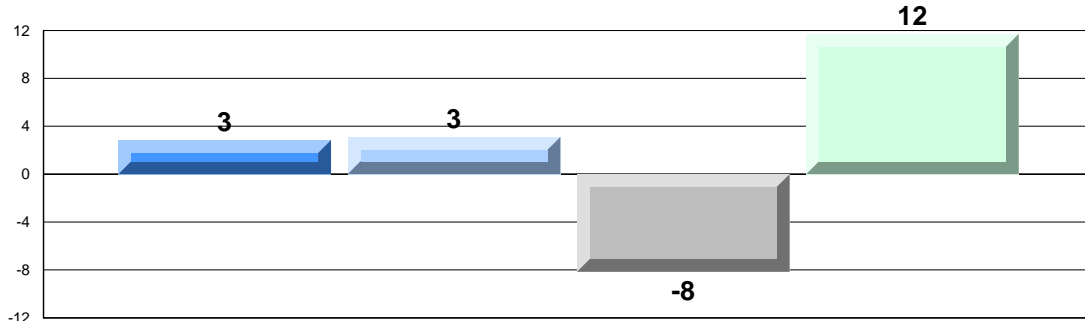

Reading

**Difference from Provincial Mean, 2010-13**

**Written Response: Percentage of students meeting/exceeding grade level expectations 2010-2013**

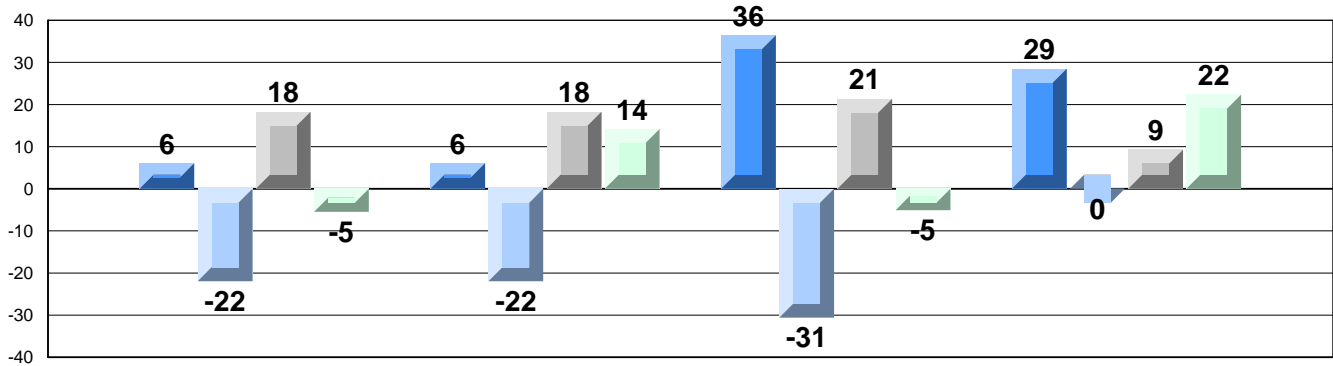

Demand Writing  
Creative

Demand Writing  
Persuasive

Non - Fiction  
Reading

Poetic/Fiction  
Reading

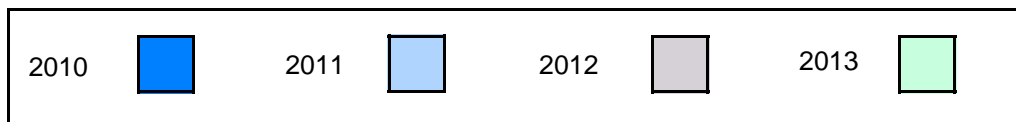

Number of Students : 11

**Multiple Choice**

**Reading**

School  
District  
Province

**Mark**

62.1  
71.4  
72.7

School  
vs  
District



School  
vs  
Province



**Closed Responses\***

**Demand Writing (Creative)**

School  
District  
Province

50.0  
66.5  
68.0



**Demand Writing (Persuasive)**

School  
District  
Province

33.3  
61.0  
60.8



**Non - Fiction Reading**

School  
District  
Province

70.0  
79.9  
80.1



**Fiction Reading**

School  
District  
Province

27.3  
62.1  
65.1



\* How to interpret the results for Closed Responses

On the Demand Writing (Creative) section, the students in Gill Memorial Academy scored 50.0%. This means 50.0% of the students met or exceeded the cut score for this section.

4 Year CRT (Subtest) Mark Trend 2010-2013  
Multiple Choice

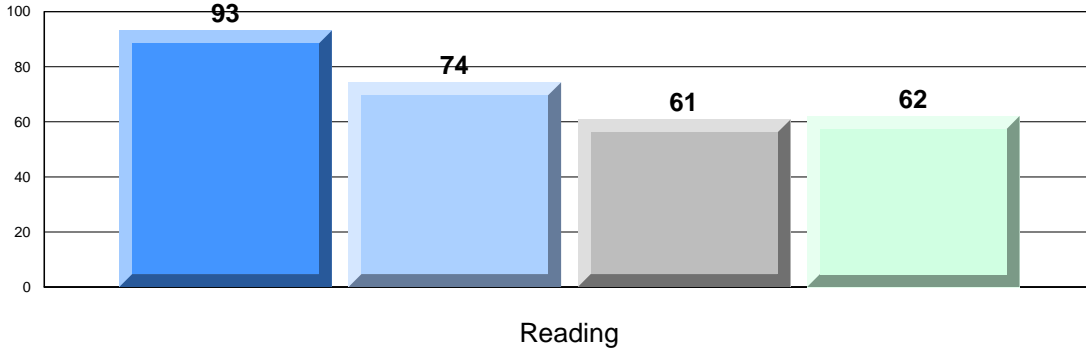

Written Response: Percentage of students meeting/exceeding grade level expectations 2010-2013

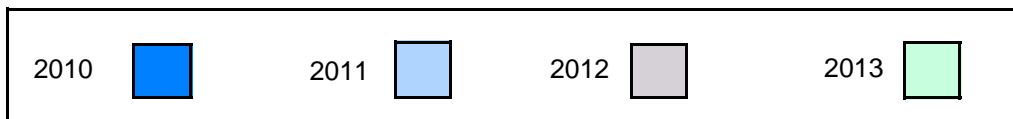
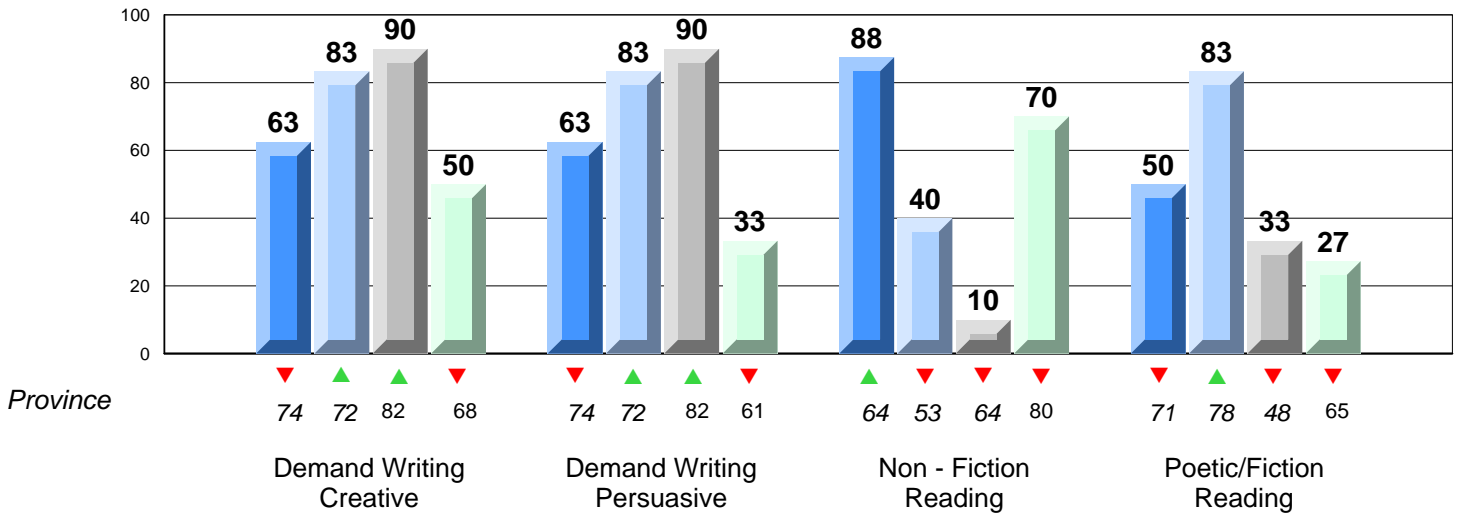

**Difference from Provincial Mean, 2010-13**

Multiple Choice

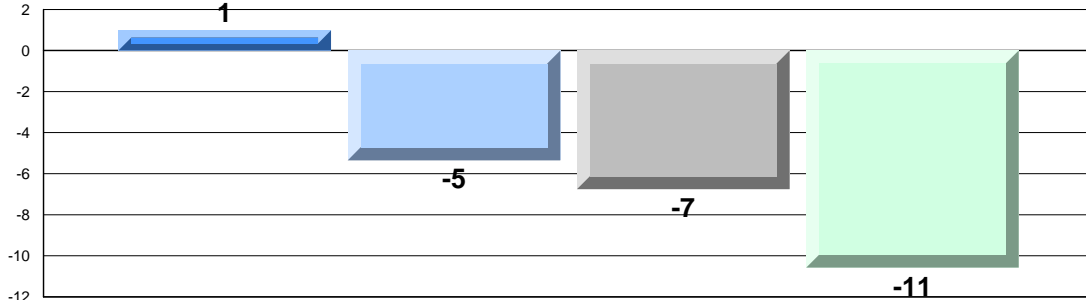

Reading

**Difference from Provincial Mean, 2010-13**

Written Response: Percentage of students meeting/exceeding grade level expectations 2010-2013

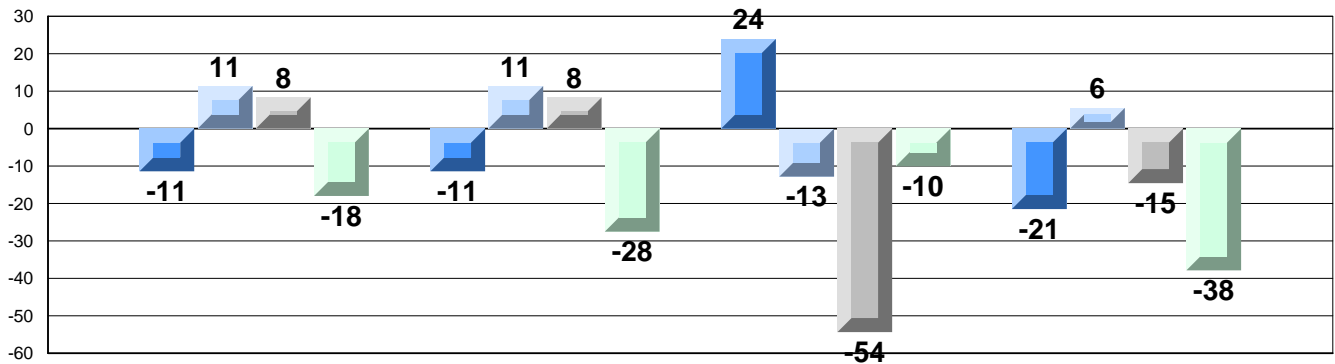

Demand Writing  
Creative

Demand Writing  
Persuasive

Non - Fiction  
Reading

Poetic/Fiction  
Reading



Number of Students : 12

**Multiple Choice**

**Reading**

School  
District  
Province

**Mark**

School  
vs  
District

School  
vs  
Province

73.2  
71.4  
72.7



**Closed Responses\***

**Demand Writing (Creative)**

School  
District  
Province

91.7  
66.5  
68.0



**Demand Writing (Persuasive)**

School  
District  
Province

58.3  
61.0  
60.8



**Non - Fiction Reading**

School  
District  
Province

90.9  
79.9  
80.1



**Fiction Reading**

School  
District  
Province

54.5  
62.1  
65.1



\* How to interpret the results for Closed Responses

On the Demand Writing (Creative) section, the students in Twillingate Island Elementary scored 91.7%. This means 91.7% of the students met or exceeded the cut score for this section.

4 Year CRT (Subtest) Mark Trend 2010-2013  
Multiple Choice

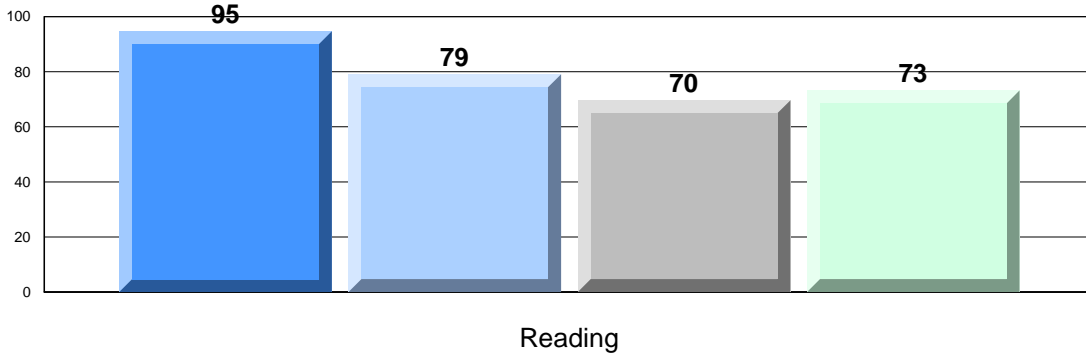

Written Response: Percentage of students meeting/exceeding grade level expectations 2010-2013

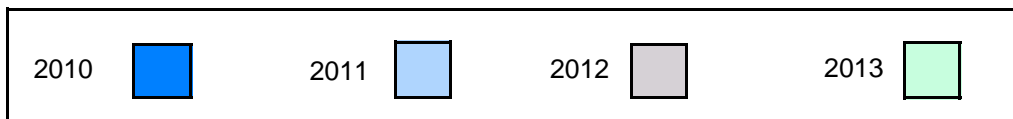
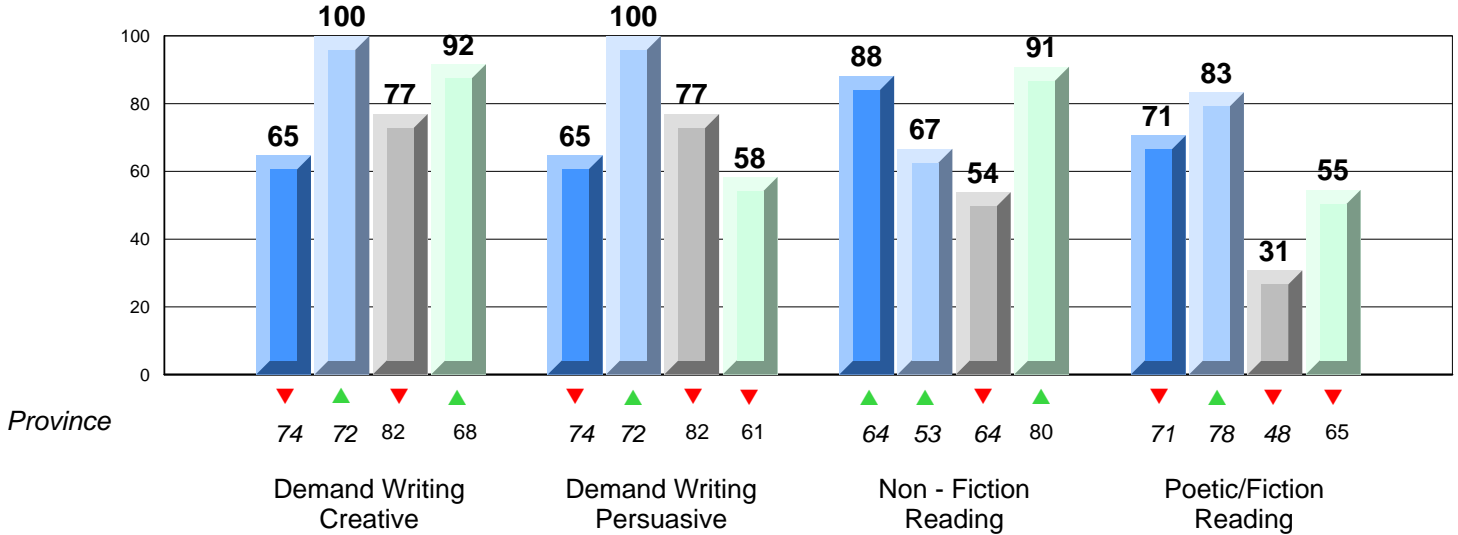

**Difference from Provincial Mean, 2010-13**

Multiple Choice

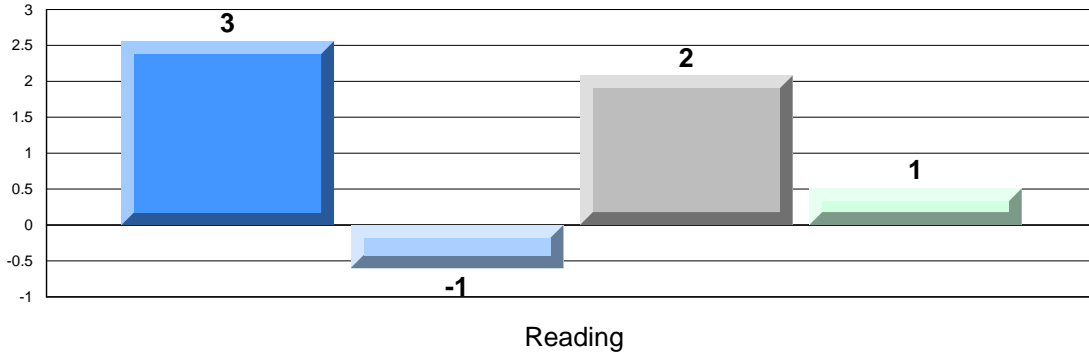

**Difference from Provincial Mean, 2010-13**

Written Response: Percentage of students meeting/exceeding grade level expectations 2010-2013

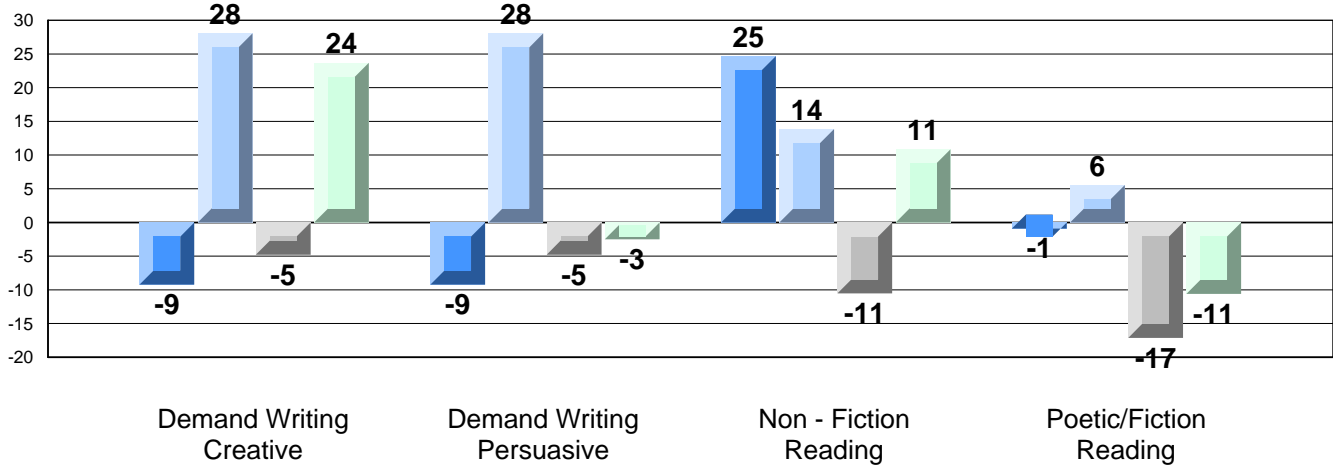

Number of Students : 12

**Multiple Choice**

**Reading**

School  
District  
Province

**Mark**

School  
vs  
District

School  
vs  
Province

72.6  
71.4  
72.7



**Closed Responses\***

**Demand Writing (Creative)**

School  
District  
Province

75.0  
66.5  
68.0



**Demand Writing (Persuasive)**

School  
District  
Province

33.3  
61.0  
60.8



**Non - Fiction Reading**

School  
District  
Province

77.8  
79.9  
80.1



**Fiction Reading**

School  
District  
Province

66.7  
62.1  
65.1



\* How to interpret the results for Closed Responses

On the Demand Writing (Creative) section, the students in Pearson Academy scored 75.0%. This means 75.0% of the students met or exceeded the cut score for this section.



4 Year CRT (Subtest) Mark Trend 2010-2013  
Multiple Choice

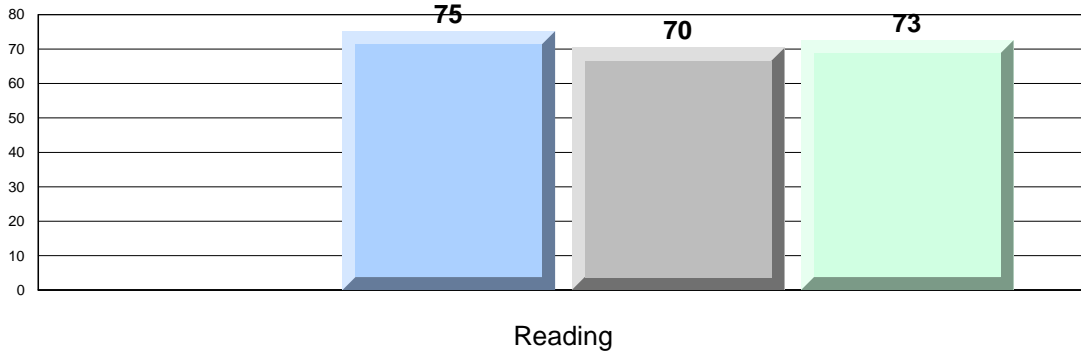

Written Response: Percentage of students meeting/exceeding grade level expectations 2010-2013

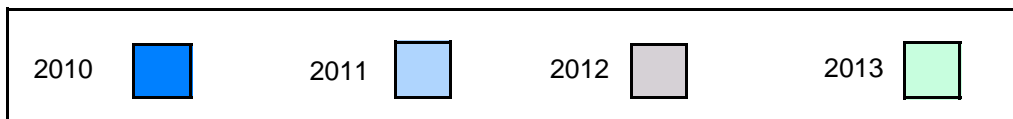
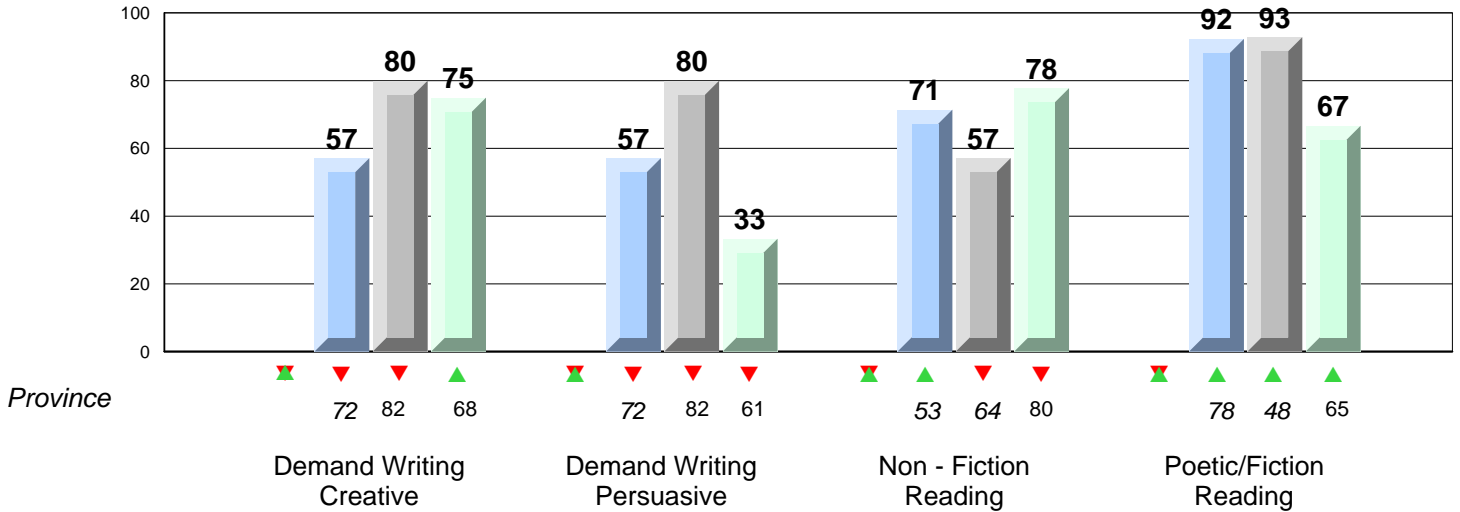

**Difference from Provincial Mean, 2010-13**

Multiple Choice

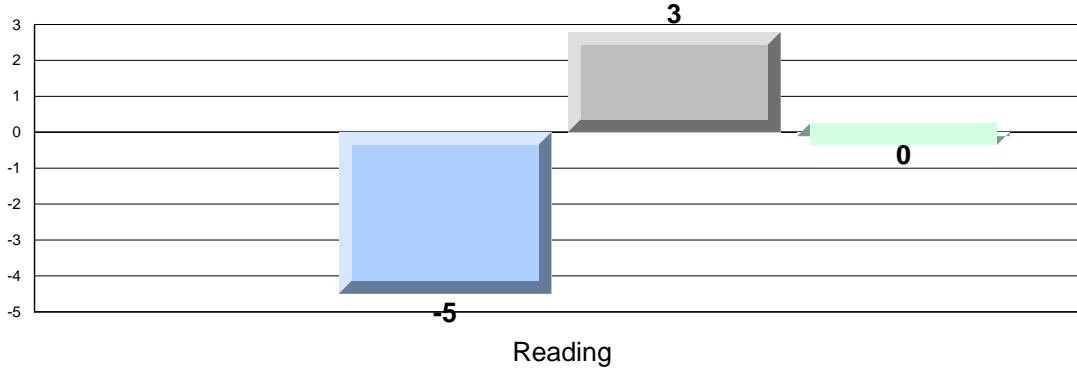

**Difference from Provincial Mean, 2010-13**

Written Response: Percentage of students meeting/exceeding grade level expectations 2010-2013

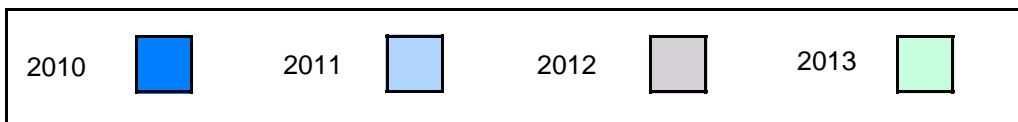
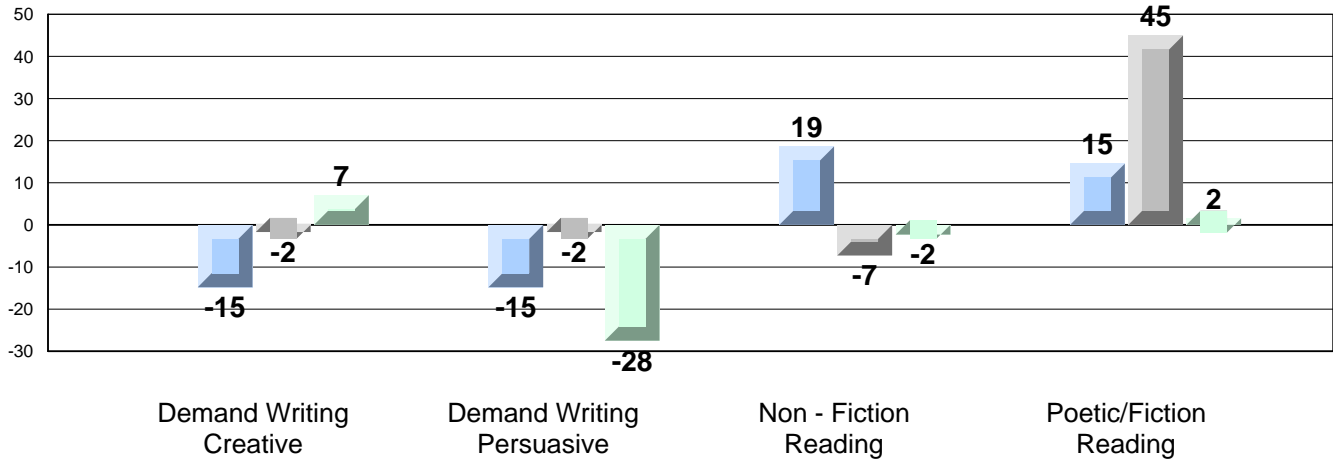

Number of Students : 20

**Multiple Choice**

**Reading**

School  
District  
Province

**Mark**

66.7  
71.4  
72.7

School  
vs  
District



School  
vs  
Province



**Closed Responses\***

**Demand Writing (Creative)**

School  
District  
Province

57.9  
66.5  
68.0



**Demand Writing (Persuasive)**

School  
District  
Province

73.7  
61.0  
60.8



**Non - Fiction Reading**

School  
District  
Province

55.6  
79.9  
80.1



**Fiction Reading**

School  
District  
Province

35.7  
62.1  
65.1



\* How to interpret the results for Closed Responses

On the Demand Writing (Creative) section, the students in Riverwood Academy scored 57.9%. This means 57.9% of the students met or exceeded the cut score for this section.

4 Year CRT (Subtest) Mark Trend 2010-2013  
Multiple Choice

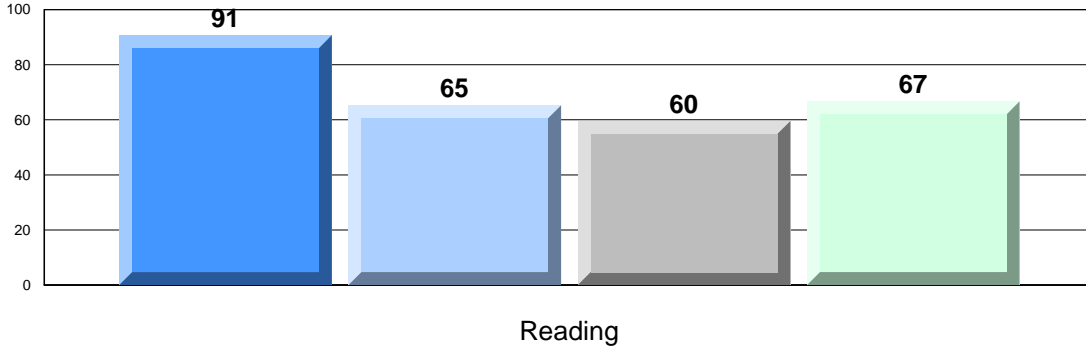

Written Response: Percentage of students meeting/exceeding grade level expectations 2010-2013

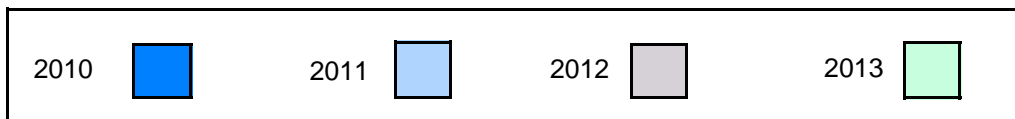
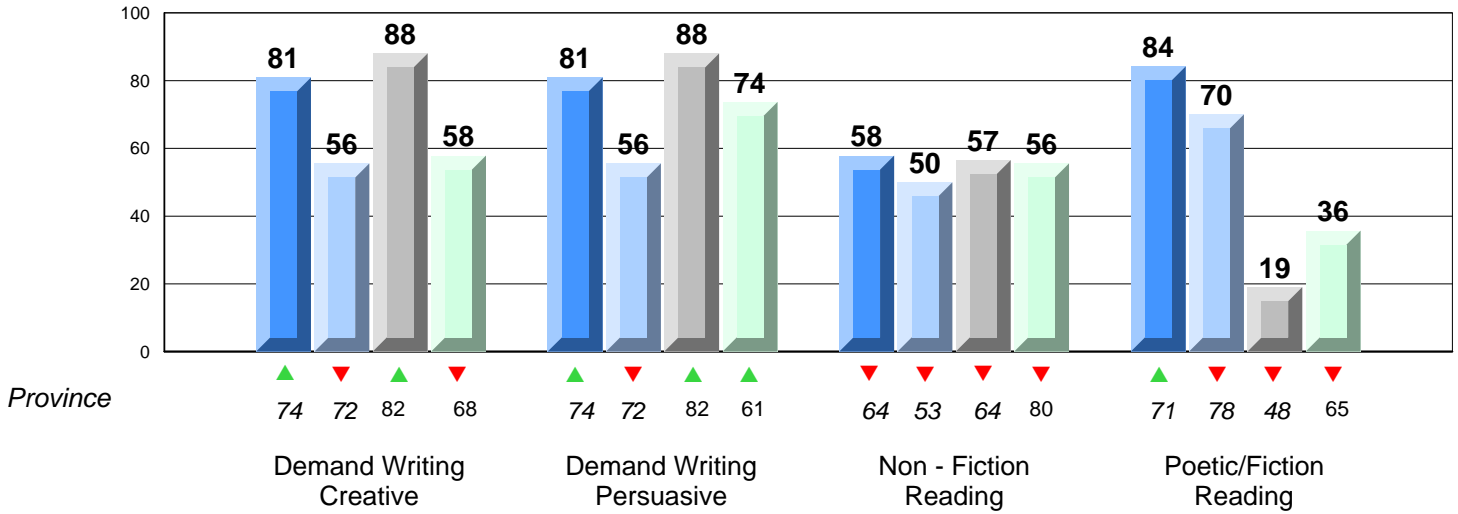

**Difference from Provincial Mean, 2010-13**

Multiple Choice

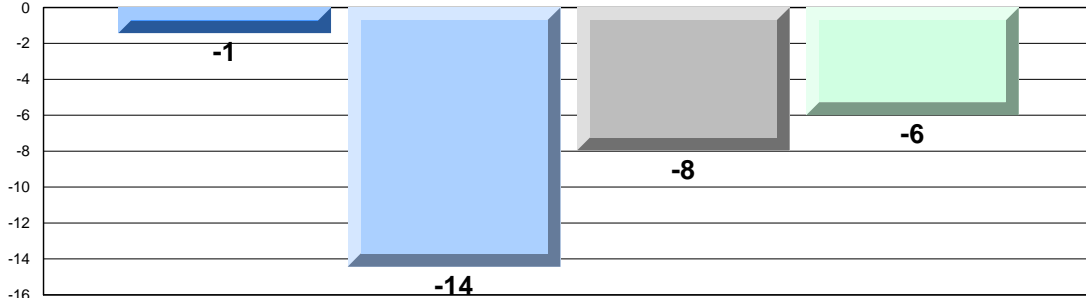

Reading

**Difference from Provincial Mean, 2010-13**

Written Response: Percentage of students meeting/exceeding grade level expectations 2010-2013

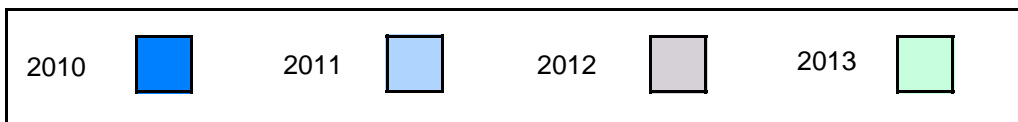
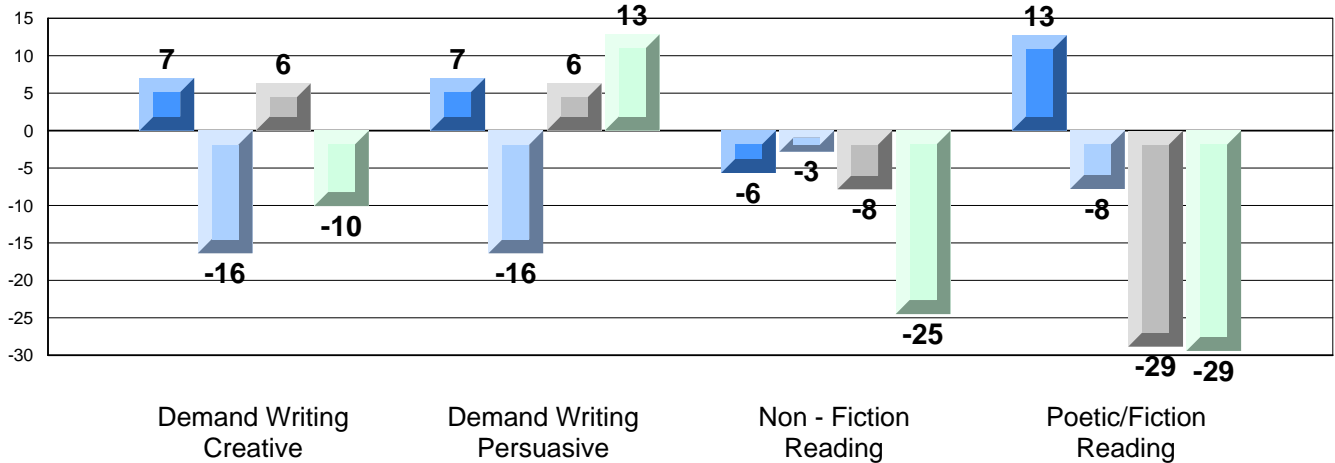

Number of Students : 8

**Multiple Choice**

**Reading**

School  
District  
Province

**Mark**

78.3  
71.4  
72.7

School  
vs  
District



School  
vs  
Province



**Closed Responses\***

**Demand Writing (Creative)**

School  
District  
Province

87.5  
66.5  
68.0



**Demand Writing (Persuasive)**

School  
District  
Province

85.7  
61.0  
60.8



**Non - Fiction Reading**

School  
District  
Province

83.3  
79.9  
80.1



**Fiction Reading**

School  
District  
Province

83.3  
62.1  
65.1



\* How to interpret the results for Closed Responses

On the Demand Writing (Creative) section, the students in Avoca Collegiate scored 87.5%. This means 87.5% of the students met or exceeded the cut score for this section.

4 Year CRT (Subtest) Mark Trend 2010-2013  
Multiple Choice

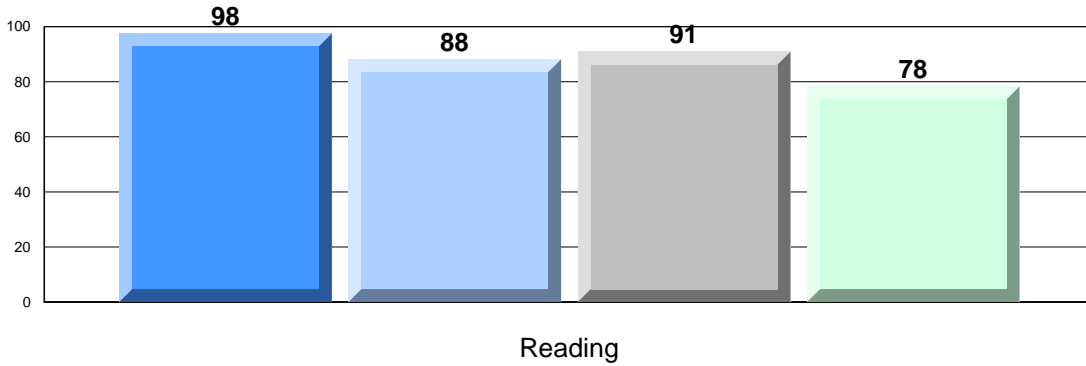

Written Response: Percentage of students meeting/exceeding grade level expectations 2010-2013

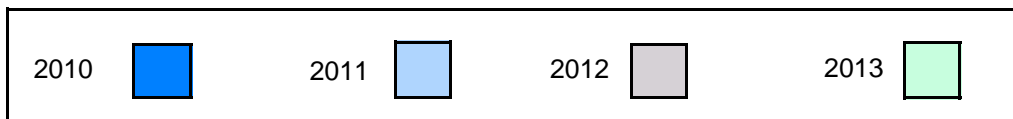
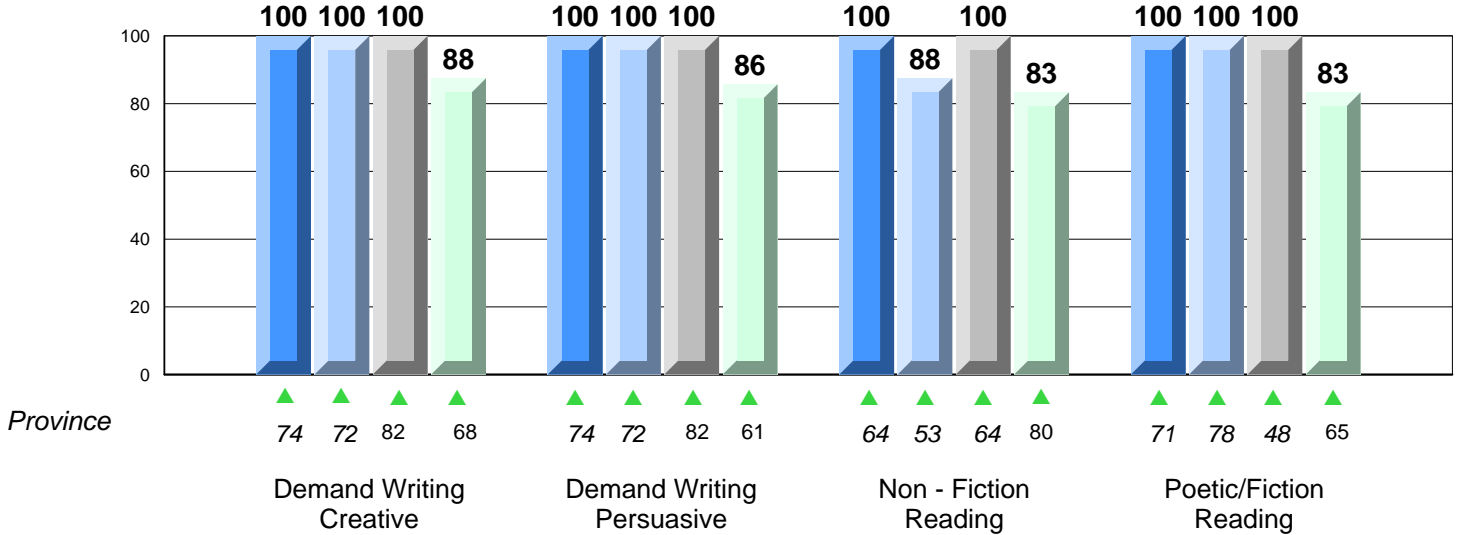

**Difference from Provincial Mean, 2010-13**

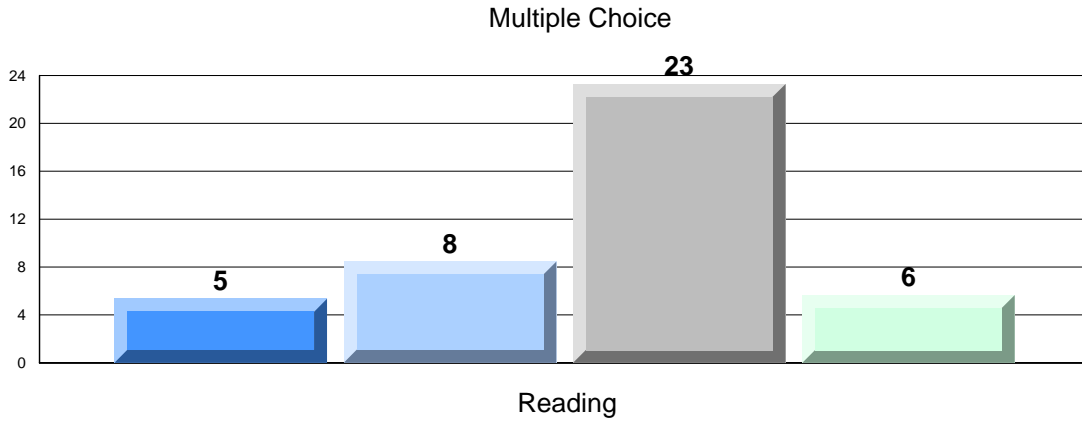

**Difference from Provincial Mean, 2010-13**

**Written Response: Percentage of students meeting/exceeding grade level expectations 2010-2013**

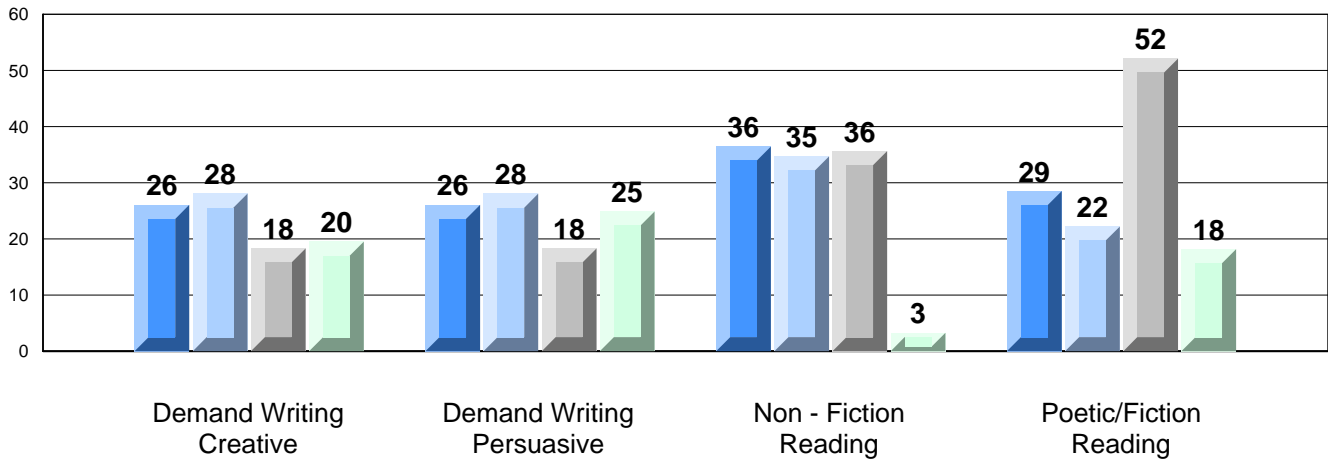



Number of Students : 29

**Multiple Choice**

**Reading**

School  
District  
Province

**Mark**

71.1  
71.4  
72.7

School  
vs  
District



School  
vs  
Province



**Closed Responses\***

**Demand Writing (Creative)**

School  
District  
Province

50.0  
66.5  
68.0



**Demand Writing (Persuasive)**

School  
District  
Province

42.9  
61.0  
60.8



**Non - Fiction Reading**

School  
District  
Province

85.7  
79.9  
80.1



**Fiction Reading**

School  
District  
Province

70.0  
62.1  
65.1



\* How to interpret the results for Closed Responses

On the Demand Writing (Creative) section, the students in Helen Tulk Elementary scored 50.0%. This means 50.0% of the students met or exceeded the cut score for this section.

4 Year CRT (Subtest) Mark Trend 2010-2013  
Multiple Choice

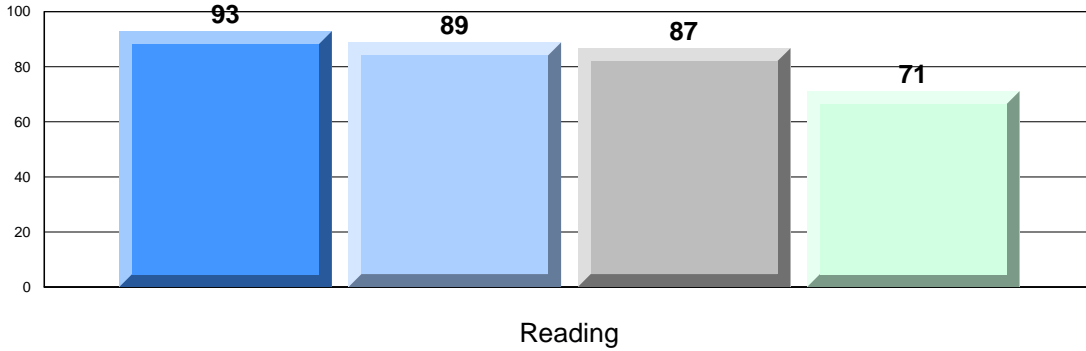

Written Response: Percentage of students meeting/exceeding grade level expectations 2010-2013

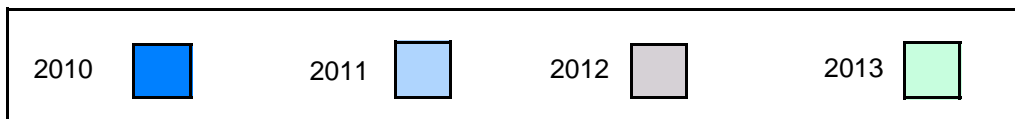
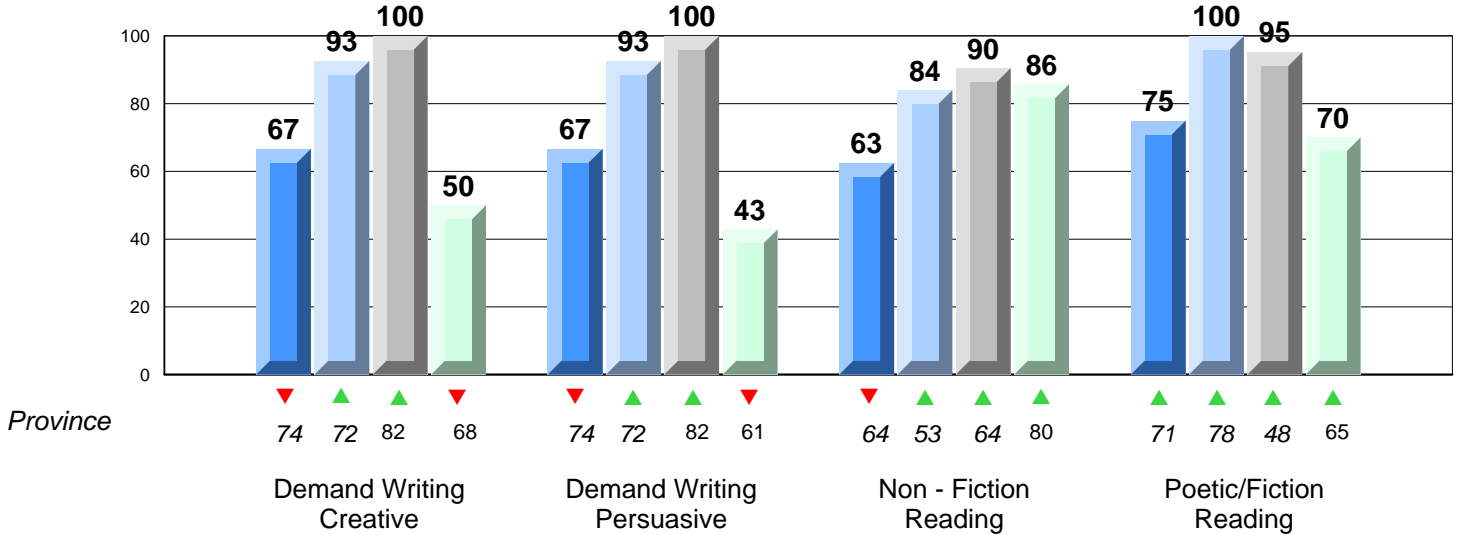

**Difference from Provincial Mean, 2010-13**

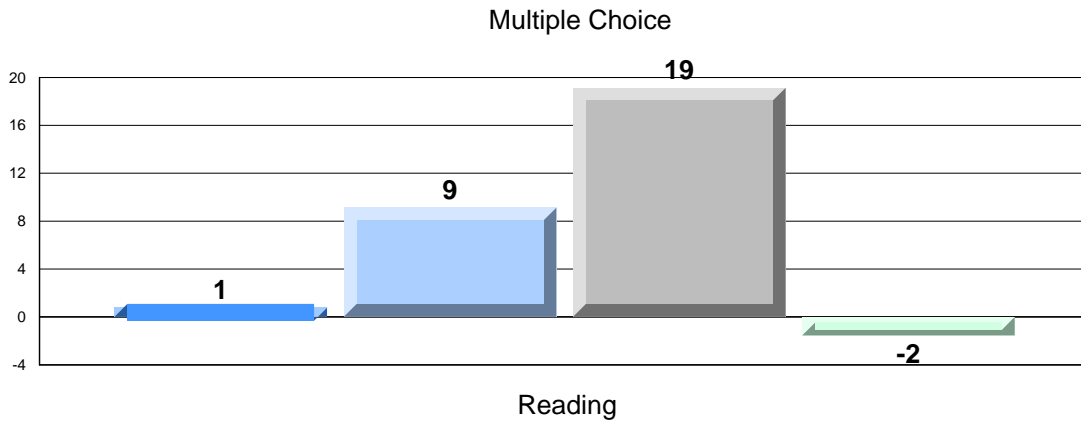

**Difference from Provincial Mean, 2010-13**

**Written Response: Percentage of students meeting/exceeding grade level expectations 2010-2013**

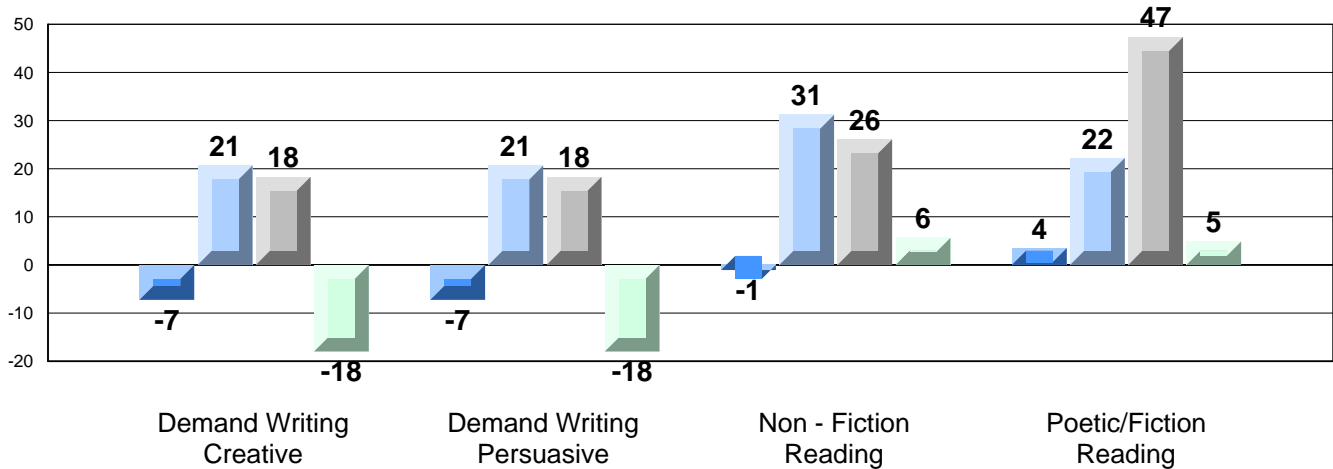

Number of Students : 4

**Multiple Choice**

**Reading**

School  
District  
Province

**Mark**

School  
vs  
District

School  
vs  
Province

School data  
with 5 or fewer  
students  
withheld for  
reasons of  
confidentiality.



**Closed Responses\***

**Demand Writing (Creative)**

School  
District  
Province



**Demand Writing (Persuasive)**

School  
District  
Province



**Non - Fiction Reading**

School  
District  
Province



**Fiction Reading**

School  
District  
Province



\* How to interpret the results for Closed Responses

On the Demand Writing (Creative) section, the students in Lakeside Academy scored 33.3%. This means 33.3% of the students met or exceeded the cut score for this section.

**4 Year CRT (Subtest) Mark Trend 2010-2013**  
**Multiple Choice**

School data with 5 or fewer students withheld for reasons of confidentiality.

Reading

**Written Response: Percentage of students meeting/exceeding grade level expectations 2010-2013**

School data with 5 or fewer students withheld for reasons of confidentiality.

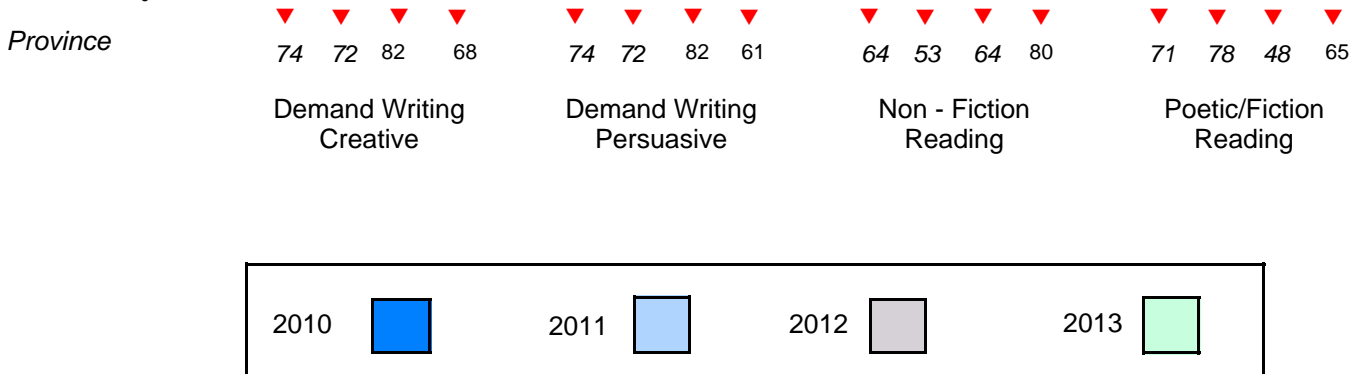

**Difference from Provincial Mean, 2010-13**

Multiple Choice

School data with 5 or fewer students withheld for reasons of confidentiality.

Reading

**Difference from Provincial Mean, 2010-13**

**Written Response: Percentage of students meeting/exceeding grade level expectations 2010-2013**

School data with 5 or fewer students withheld for reasons of confidentiality.

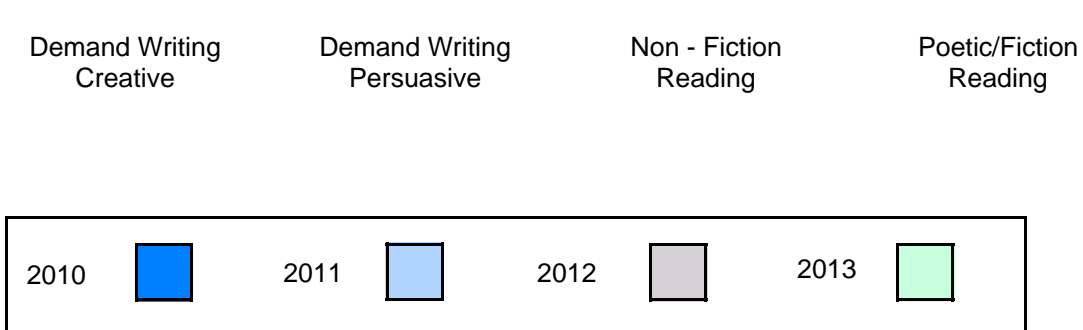

Number of Students : 1

**Multiple Choice**

**Reading**

School  
District  
Province

Mark	School vs District	School vs Province
School data with 5 or fewer students withheld for reasons of confidentiality.	▲	▲

**Closed Responses\***

**Demand Writing (Creative)**

School  
District  
Province



**Demand Writing (Persuasive)**

School  
District  
Province



**Non - Fiction Reading**

School  
District  
Province



**Fiction Reading**

School  
District  
Province



\* How to interpret the results for Closed Responses

On the Demand Writing (Creative) section, the students in Cottrell's Cove Academy scored 0.0%. This means 0.0% of the students met or exceeded the cut score for this section.

**4 Year CRT (Subtest) Mark Trend 2010-2013**  
**Multiple Choice**

School data with 5 or fewer students withheld for reasons of confidentiality.

Reading

**Written Response: Percentage of students meeting/exceeding grade level expectations 2010-2013**

School data with 5 or fewer students withheld for reasons of confidentiality.

Province

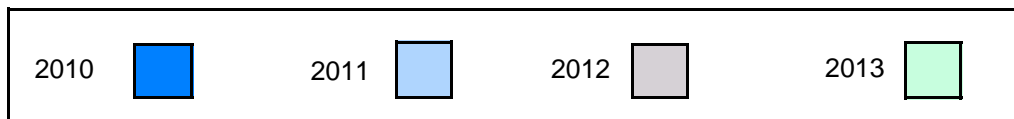
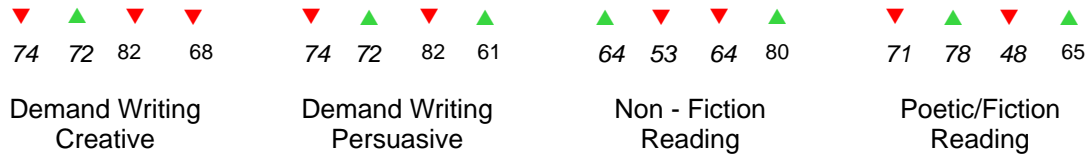



**Difference from Provincial Mean, 2010-13**

Multiple Choice

School data with 5 or fewer students withheld for reasons of confidentiality.

Reading

**Difference from Provincial Mean, 2010-13**

**Written Response: Percentage of students meeting/exceeding grade level expectations 2010-2013**

School data with 5 or fewer students withheld for reasons of confidentiality.

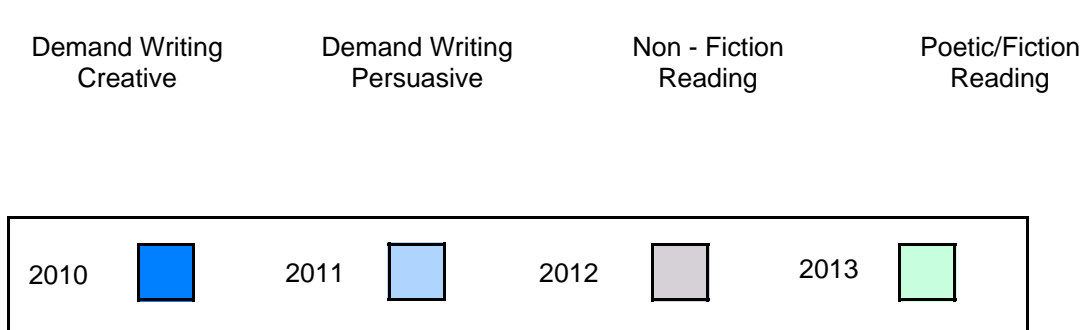

Number of Students : 10

**Multiple Choice**

**Reading**

School  
District  
Province

**Mark**

59.6  
71.4  
72.7

School  
vs  
District



School  
vs  
Province



**Closed Responses\***

**Demand Writing (Creative)**

School  
District  
Province

66.7  
66.5  
68.0



**Demand Writing (Persuasive)**

School  
District  
Province

37.5  
61.0  
60.8



**Non - Fiction Reading**

School  
District  
Province

50.0  
79.9  
80.1



**Fiction Reading**

School  
District  
Province

30.0  
62.1  
65.1



\* How to interpret the results for Closed Responses

On the Demand Writing (Creative) section, the students in Fitzgerald Academy scored 66.7%. This means 66.7% of the students met or exceeded the cut score for this section.

4 Year CRT (Subtest) Mark Trend 2010-2013  
Multiple Choice

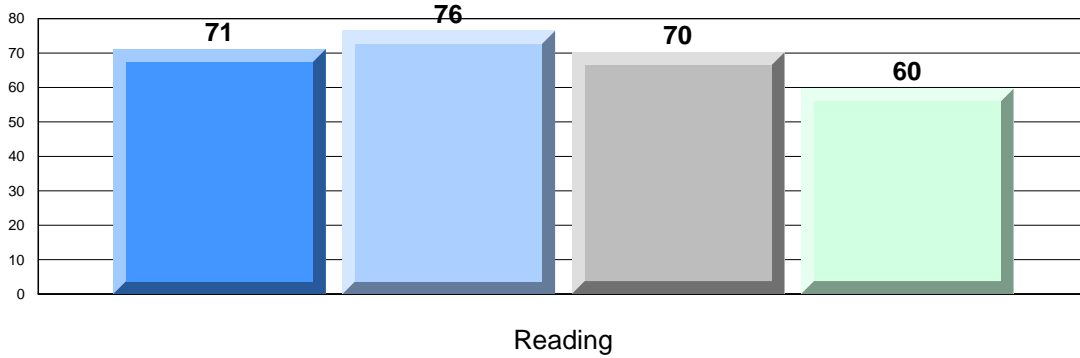

Written Response: Percentage of students meeting/exceeding grade level expectations 2010-2013

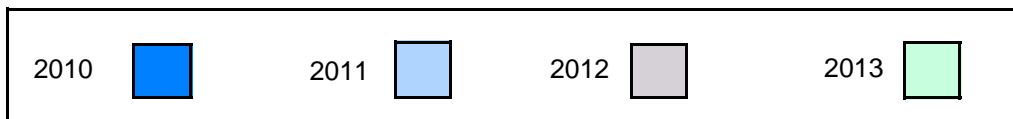
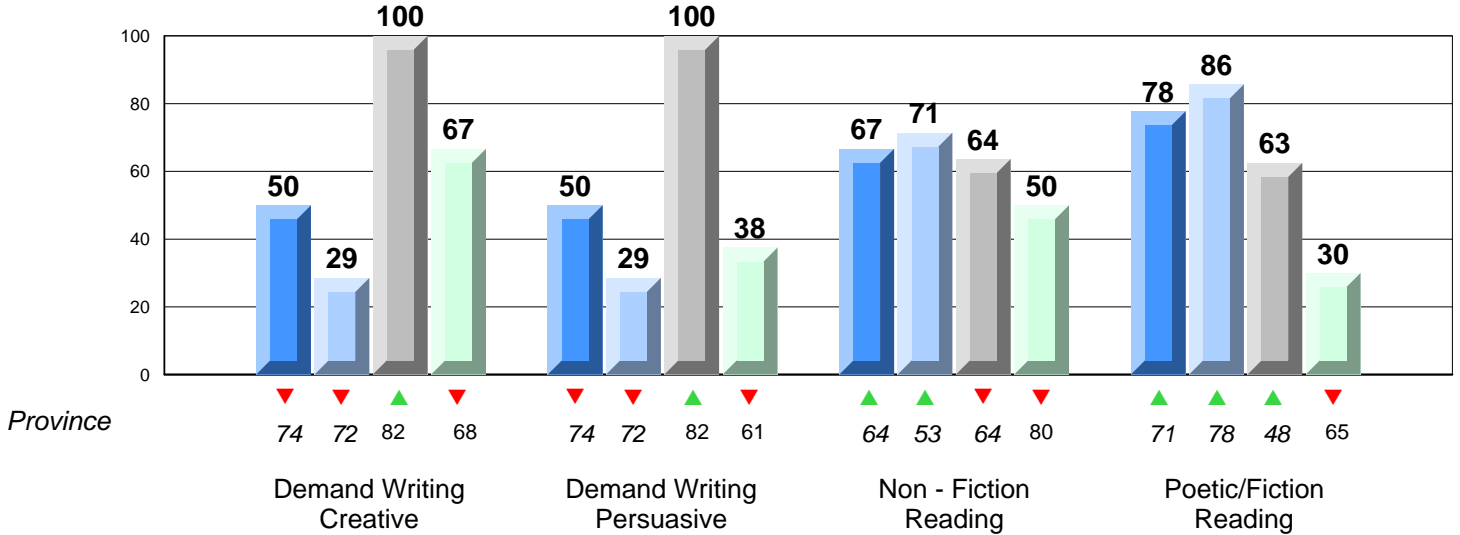

**Difference from Provincial Mean, 2010-13**

Multiple Choice

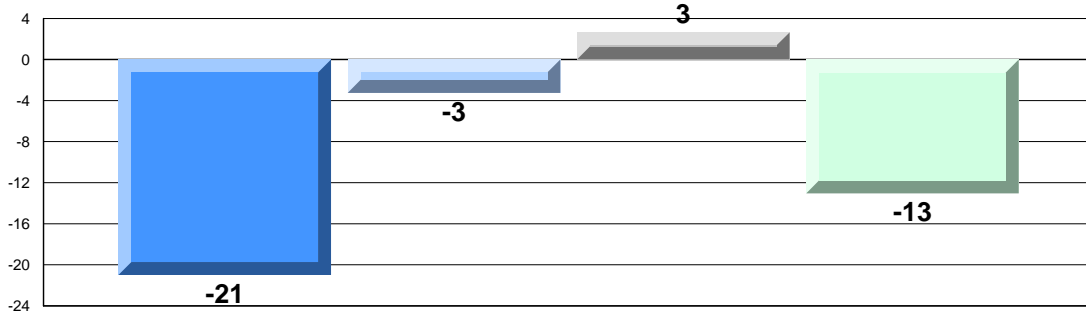

Reading

**Difference from Provincial Mean, 2010-13**

Written Response: Percentage of students meeting/exceeding grade level expectations 2010-2013

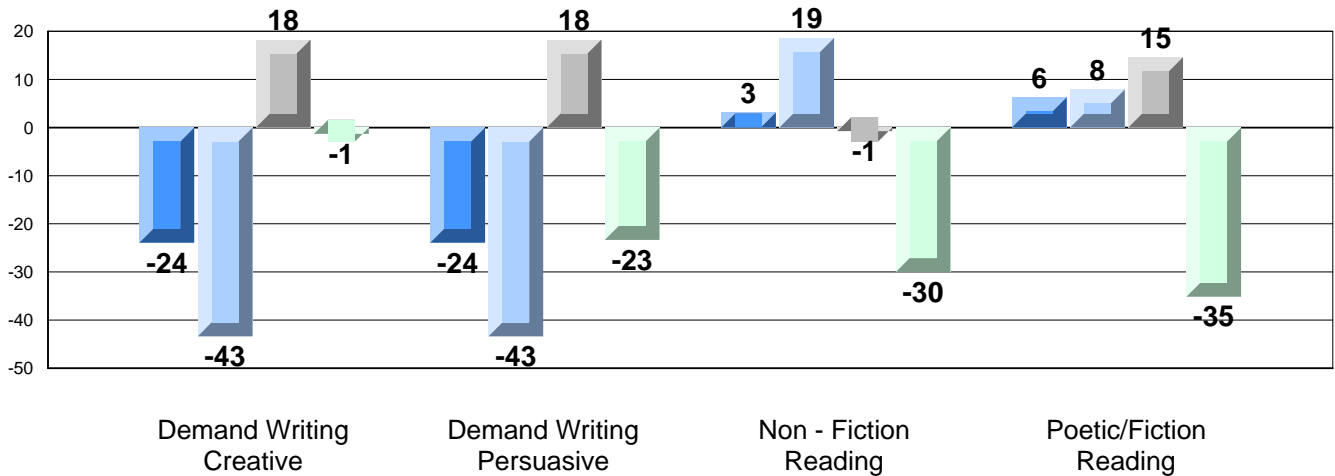

Number of Students : 16

**Multiple Choice**

**Reading**

School  
District  
Province

**Mark**

74.3  
71.4  
72.7

School  
vs  
District



School  
vs  
Province



**Closed Responses\***

**Demand Writing (Creative)**

School  
District  
Province

87.5  
66.5  
68.0



**Demand Writing (Persuasive)**

School  
District  
Province

50.0  
61.0  
60.8



**Non - Fiction Reading**

School  
District  
Province

81.3  
79.9  
80.1



**Fiction Reading**

School  
District  
Province

73.3  
62.1  
65.1



\* How to interpret the results for Closed Responses

On the Demand Writing (Creative) section, the students in Bay d'Espoir Academy scored 87.5%. This means 87.5% of the students met or exceeded the cut score for this section.

4 Year CRT (Subtest) Mark Trend 2010-2013  
Multiple Choice

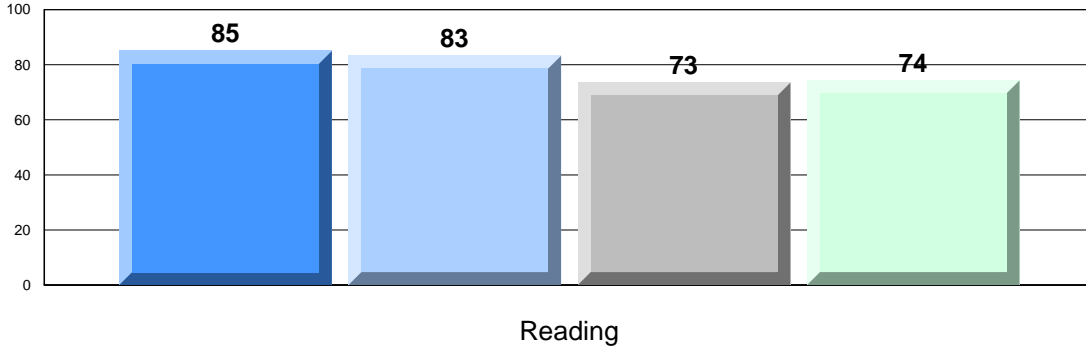

Written Response: Percentage of students meeting/exceeding grade level expectations 2010-2013

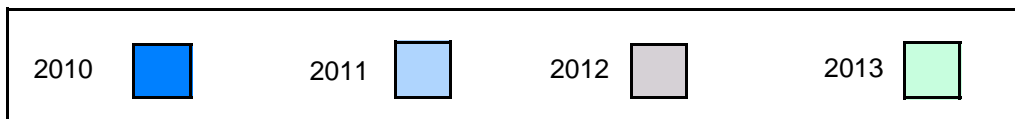
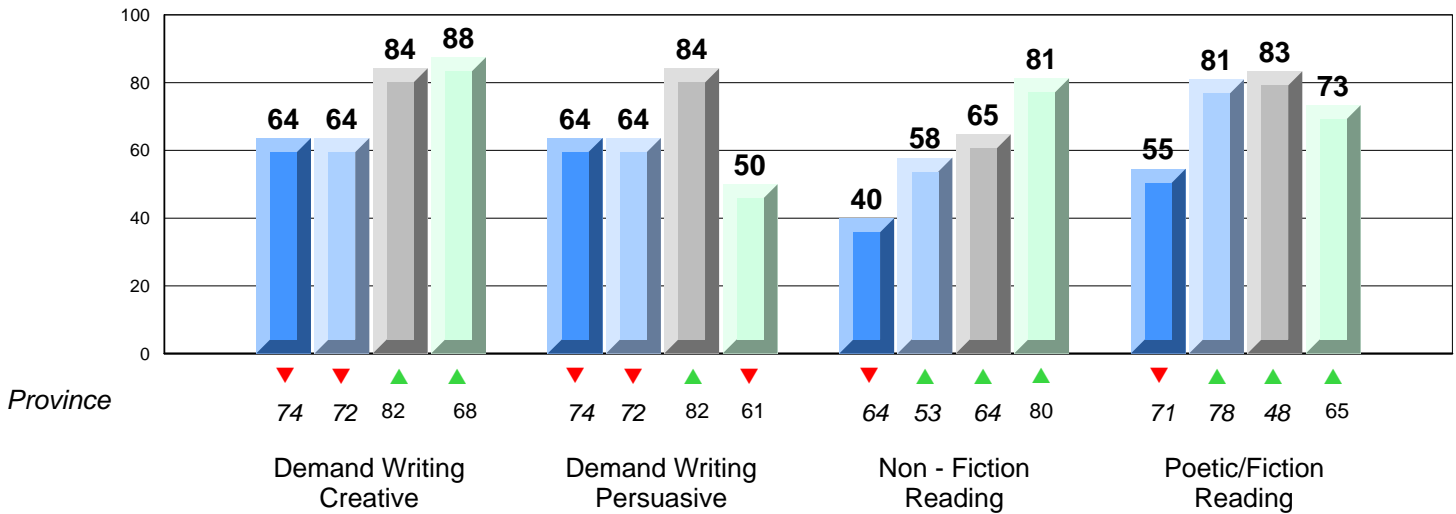

**Difference from Provincial Mean, 2010-13**

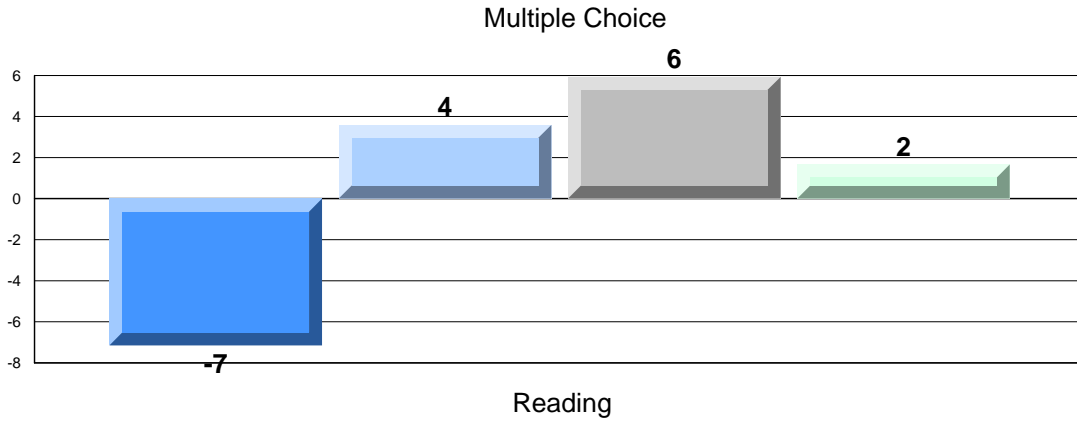

**Difference from Provincial Mean, 2010-13**

**Written Response: Percentage of students meeting/exceeding grade level expectations 2010-2013**

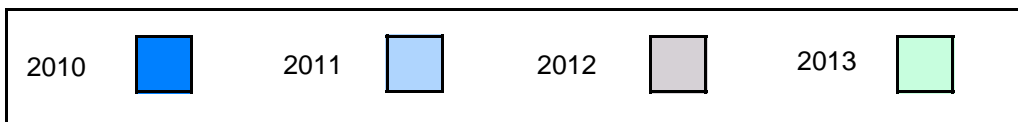
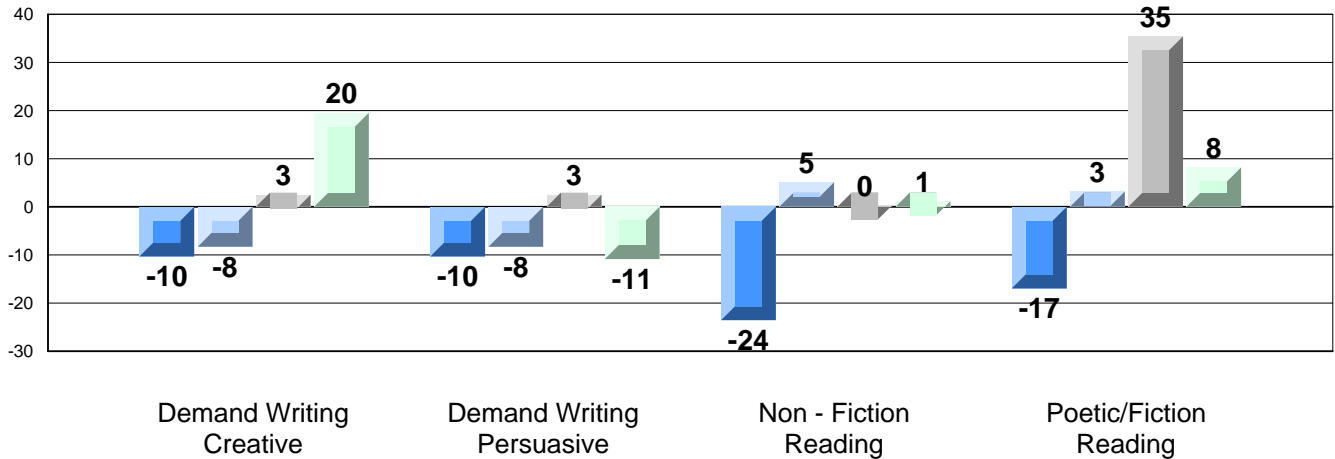

Number of Students : 25

**Multiple Choice**

**Reading**

School  
District  
Province

**Mark**

79.3  
71.4  
72.7

School  
vs  
District



School  
vs  
Province



**Closed Responses\***

**Demand Writing (Creative)**

School  
District  
Province

92.0  
66.5  
68.0



**Demand Writing (Persuasive)**

School  
District  
Province

88.0  
61.0  
60.8



**Non - Fiction Reading**

School  
District  
Province

87.0  
79.9  
80.1



**Fiction Reading**

School  
District  
Province

86.4  
62.1  
65.1



\* How to interpret the results for Closed Responses

On the Demand Writing (Creative) section, the students in Indian River Academy scored 92.0%. This means 92.0% of the students met or exceeded the cut score for this section.



4 Year CRT (Subtest) Mark Trend 2010-2013  
Multiple Choice

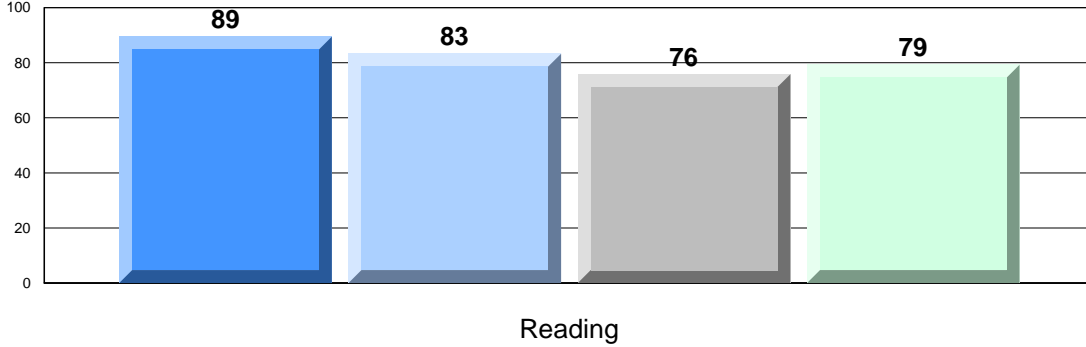

Written Response: Percentage of students meeting/exceeding grade level expectations 2010-2013

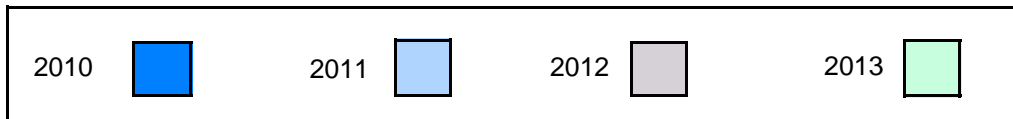
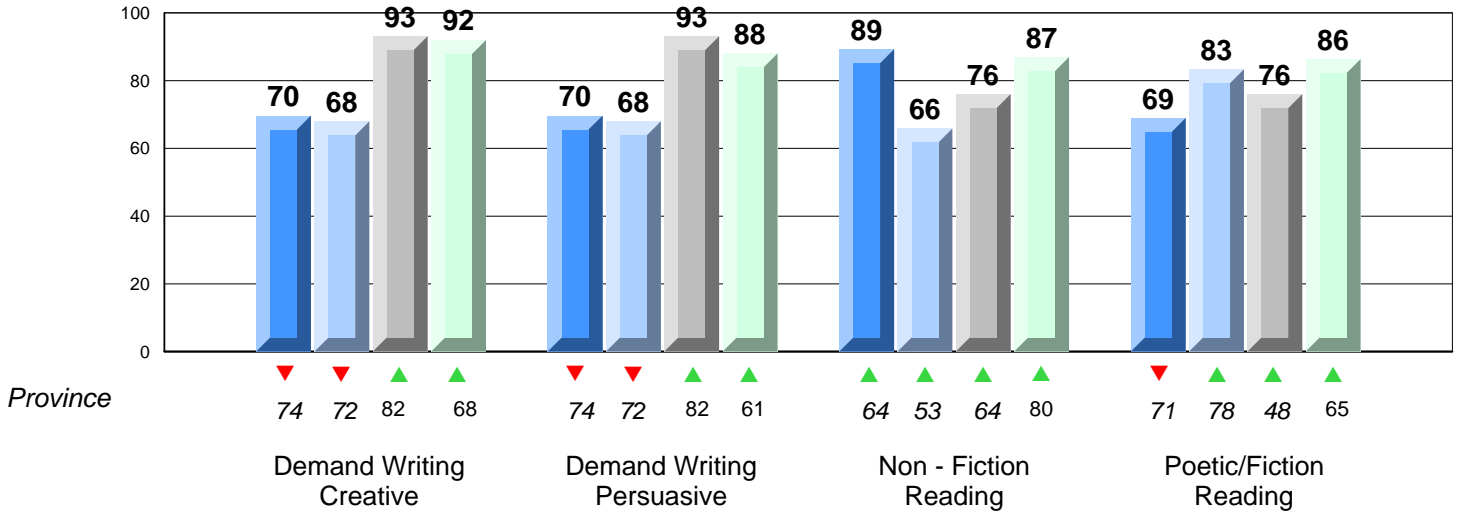

**Difference from Provincial Mean, 2010-13**

Multiple Choice

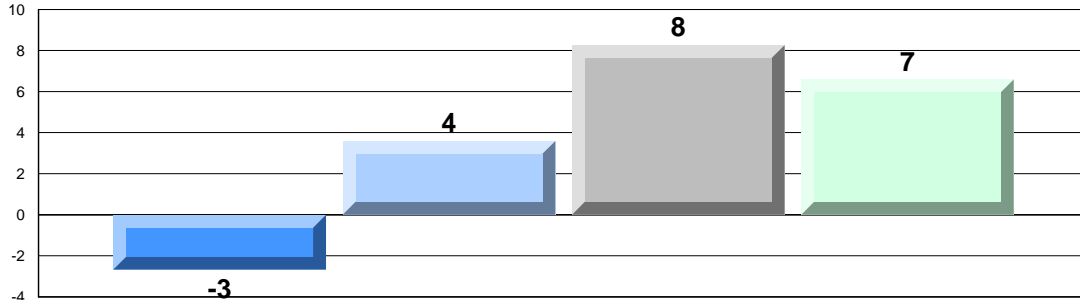

Reading

**Difference from Provincial Mean, 2010-13**

Written Response: Percentage of students meeting/exceeding grade level expectations 2010-2013

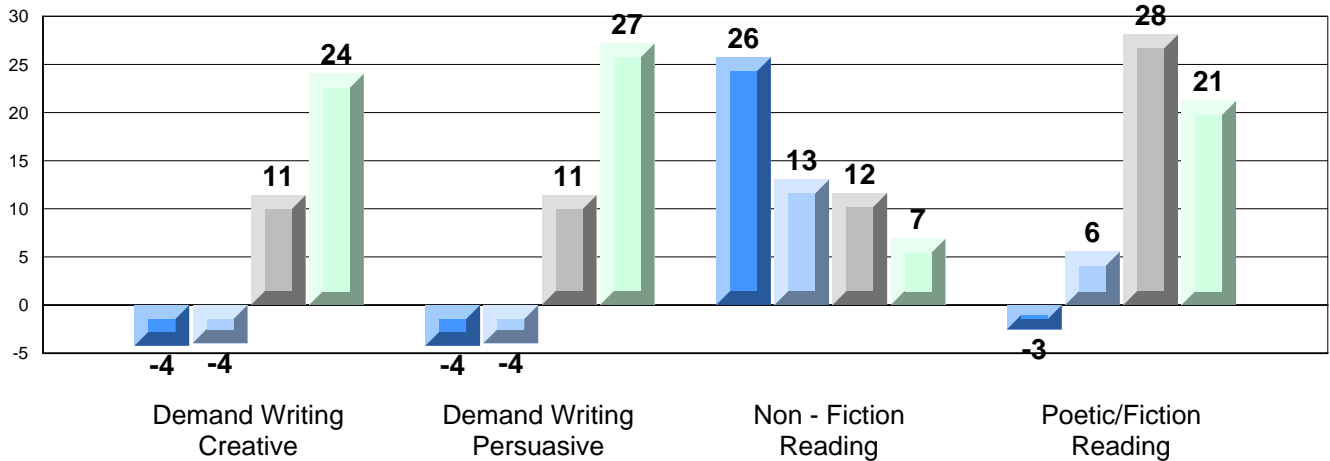

Number of Students : 9

**Multiple Choice**

**Reading**

School  
District  
Province

**Mark**

School  
vs  
District

School  
vs  
Province

84.3  
71.4  
72.7



**Closed Responses\***

**Demand Writing (Creative)**

School  
District  
Province

87.5  
66.5  
68.0



**Demand Writing (Persuasive)**

School  
District  
Province

77.8  
61.0  
60.8



**Non - Fiction Reading**

School  
District  
Province

100.0  
79.9  
80.1



**Fiction Reading**

School  
District  
Province

100.0  
62.1  
65.1



\* How to interpret the results for Closed Responses

On the Demand Writing (Creative) section, the students in Holy Cross School Complex scored 87.5%. This means 87.5% of the students met or exceeded the cut score for this section.

4 Year CRT (Subtest) Mark Trend 2010-2013  
Multiple Choice

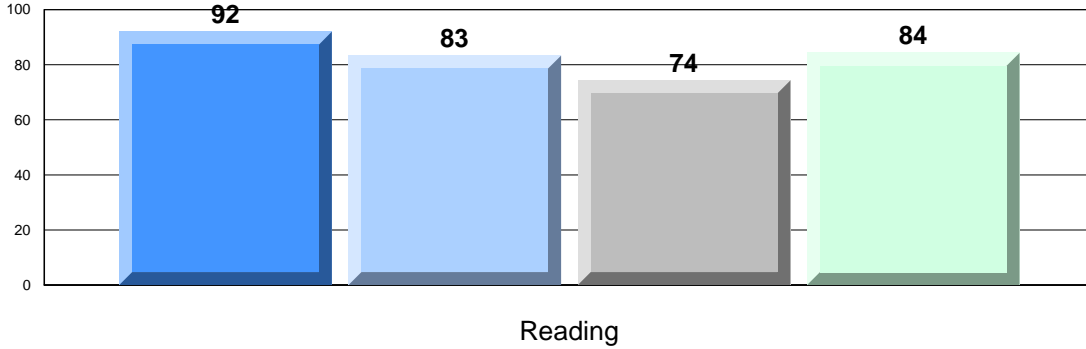

Written Response: Percentage of students meeting/exceeding grade level expectations 2010-2013

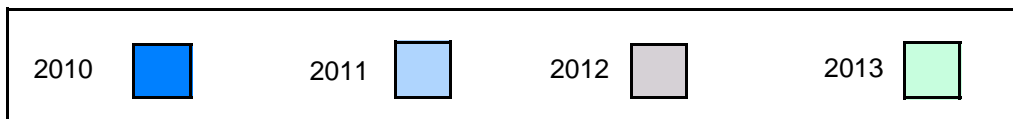
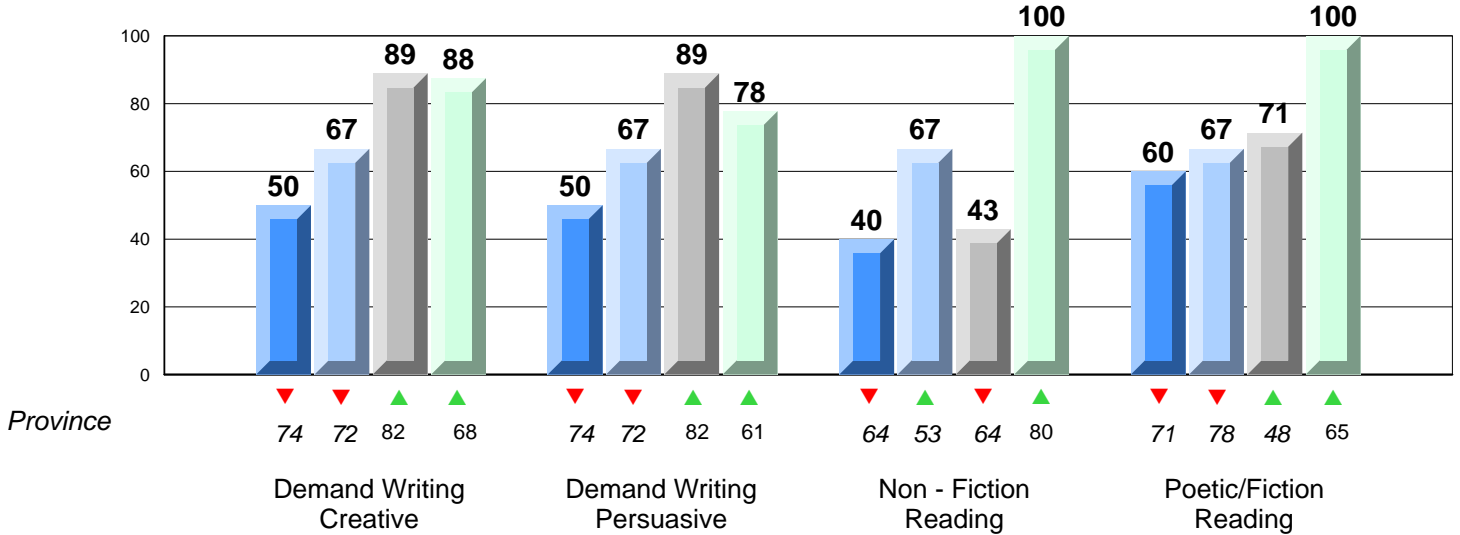

**Difference from Provincial Mean, 2010-13**

Multiple Choice

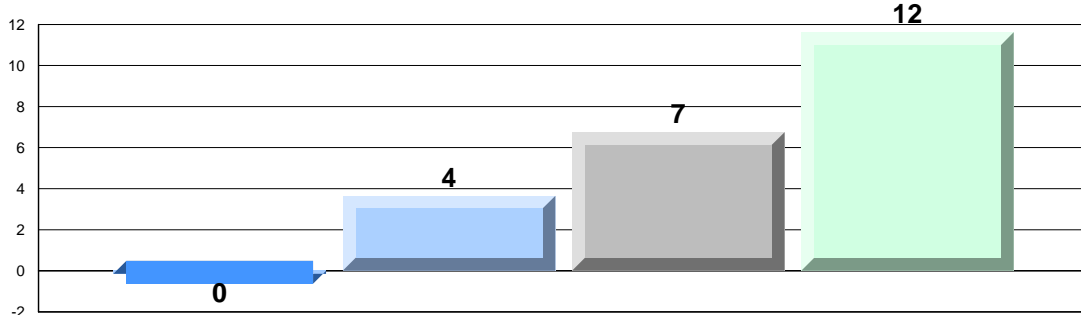

Reading

**Difference from Provincial Mean, 2010-13**

Written Response: Percentage of students meeting/exceeding grade level expectations 2010-2013

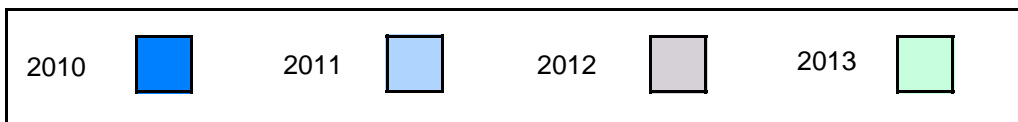
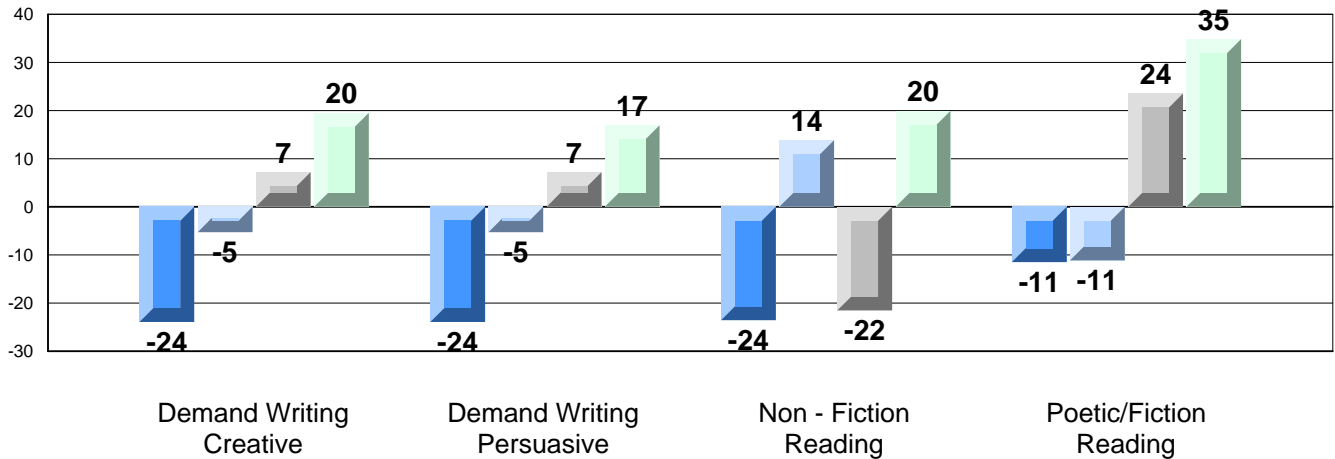

Number of Students : 23

**Multiple Choice**

**Reading**

School  
District  
Province

**Mark**

69.2  
71.4  
72.7

School  
vs  
District



School  
vs  
Province



**Closed Responses\***

**Demand Writing (Creative)**

School  
District  
Province

56.5  
66.5  
68.0



**Demand Writing (Persuasive)**

School  
District  
Province

17.4  
61.0  
60.8



**Non - Fiction Reading**

School  
District  
Province

61.9  
79.9  
80.1



**Fiction Reading**

School  
District  
Province

50.0  
62.1  
65.1



\* How to interpret the results for Closed Responses

On the Demand Writing (Creative) section, the students in Fogo Island Central Academy scored 56.5%. This means 56.5% of the students met or exceeded the cut score for this section.

4 Year CRT (Subtest) Mark Trend 2010-2013  
Multiple Choice

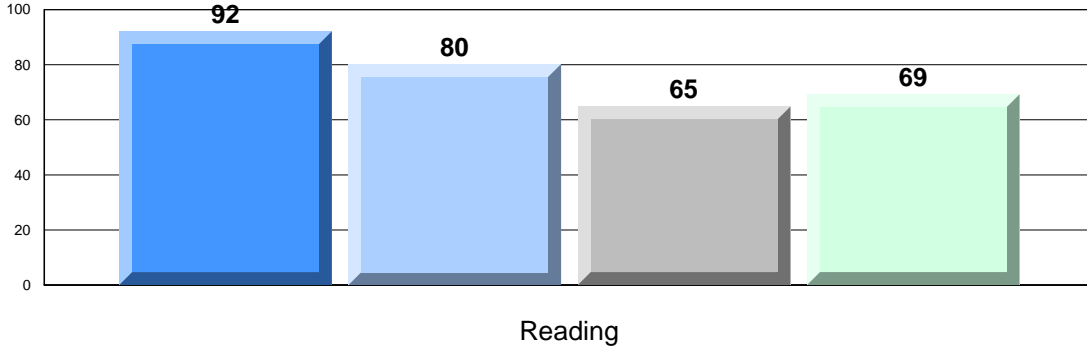

Written Response: Percentage of students meeting/exceeding grade level expectations 2010-2013

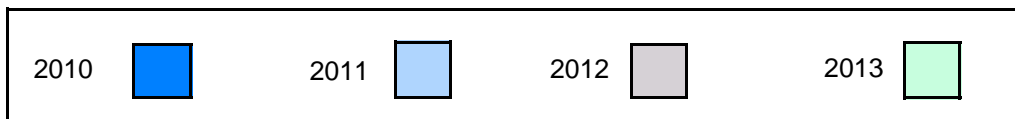
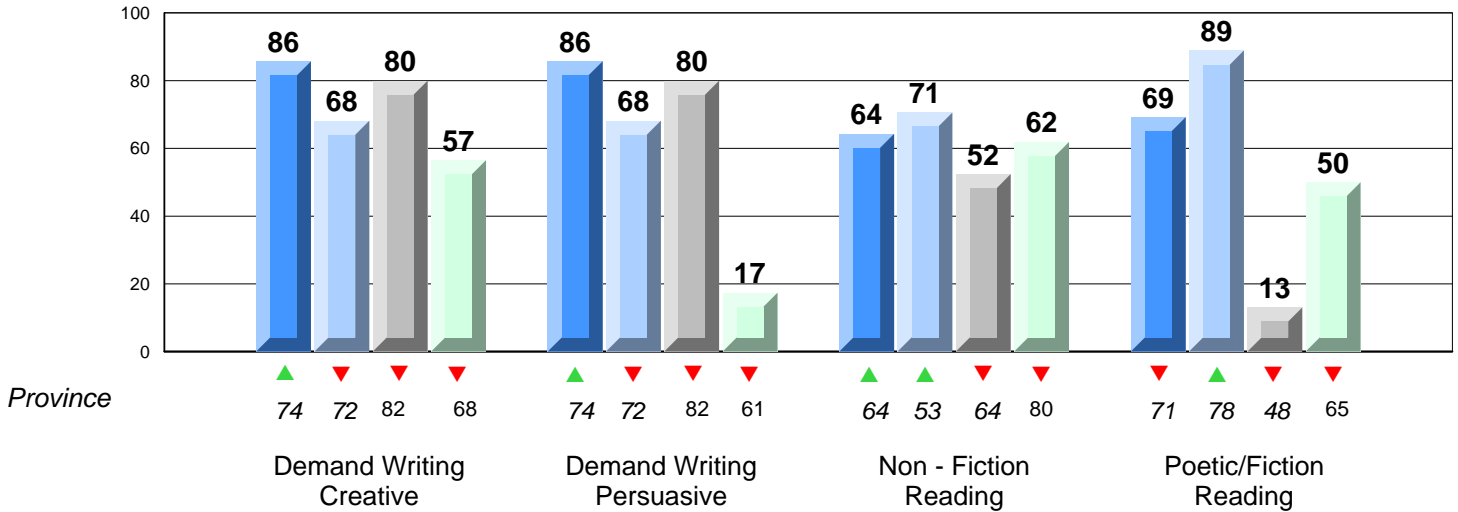

**Difference from Provincial Mean, 2010-13**

Multiple Choice

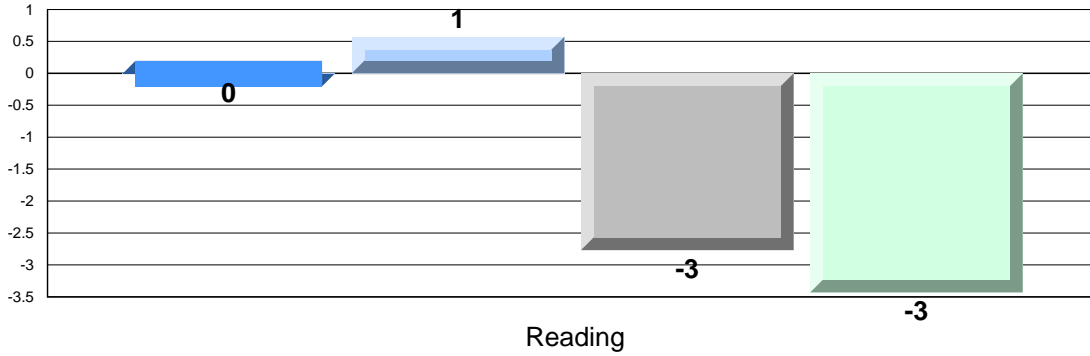

**Difference from Provincial Mean, 2010-13**

Written Response: Percentage of students meeting/exceeding grade level expectations 2010-2013

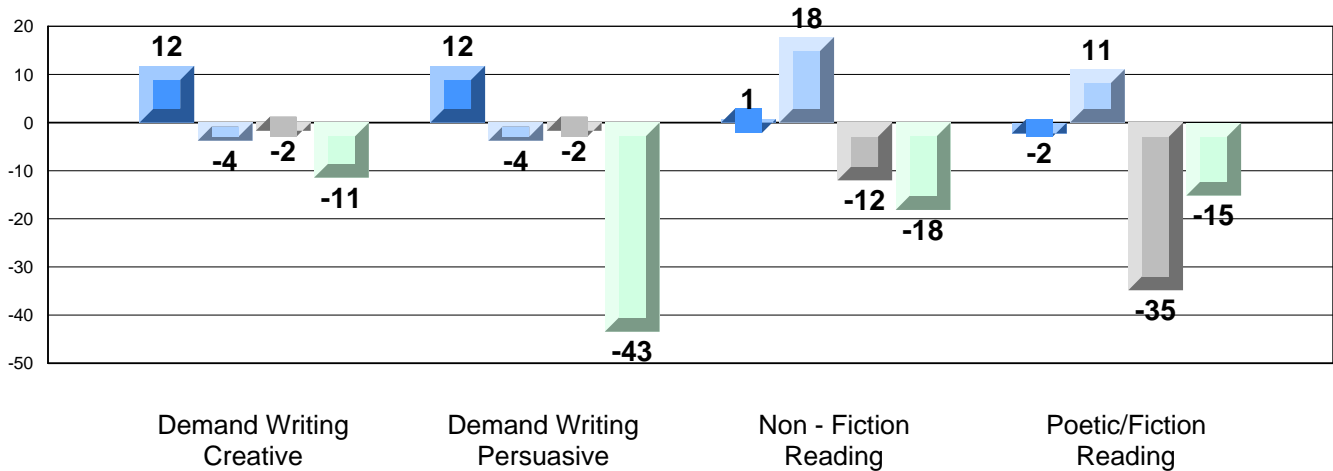



Number of Students : 14

**Multiple Choice**

**Reading**

School  
District  
Province

**Mark**

School  
vs  
District

School  
vs  
Province

78.2  
71.4  
72.7



**Closed Responses\***

**Demand Writing (Creative)**

School  
District  
Province

42.9  
66.5  
68.0



**Demand Writing (Persuasive)**

School  
District  
Province

84.6  
61.0  
60.8



**Non - Fiction Reading**

School  
District  
Province

100.0  
79.9  
80.1



**Fiction Reading**

School  
District  
Province

77.8  
62.1  
65.1



\* How to interpret the results for Closed Responses

On the Demand Writing (Creative) section, the students in Smallwood Academy scored 42.9%. This means 42.9% of the students met or exceeded the cut score for this section.

4 Year CRT (Subtest) Mark Trend 2010-2013  
Multiple Choice

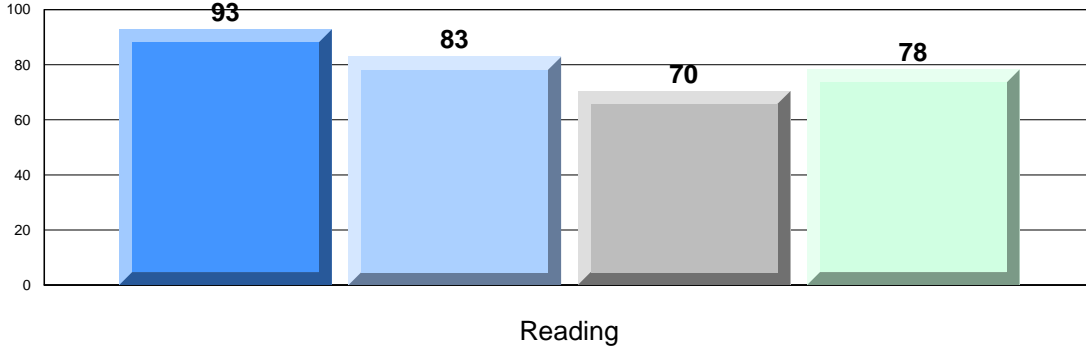

Written Response: Percentage of students meeting/exceeding grade level expectations 2010-2013

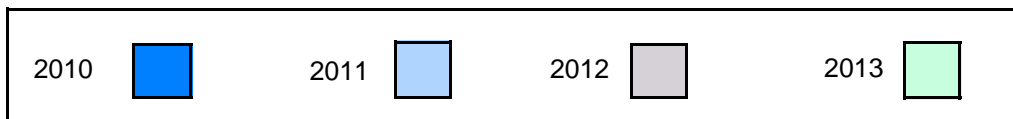
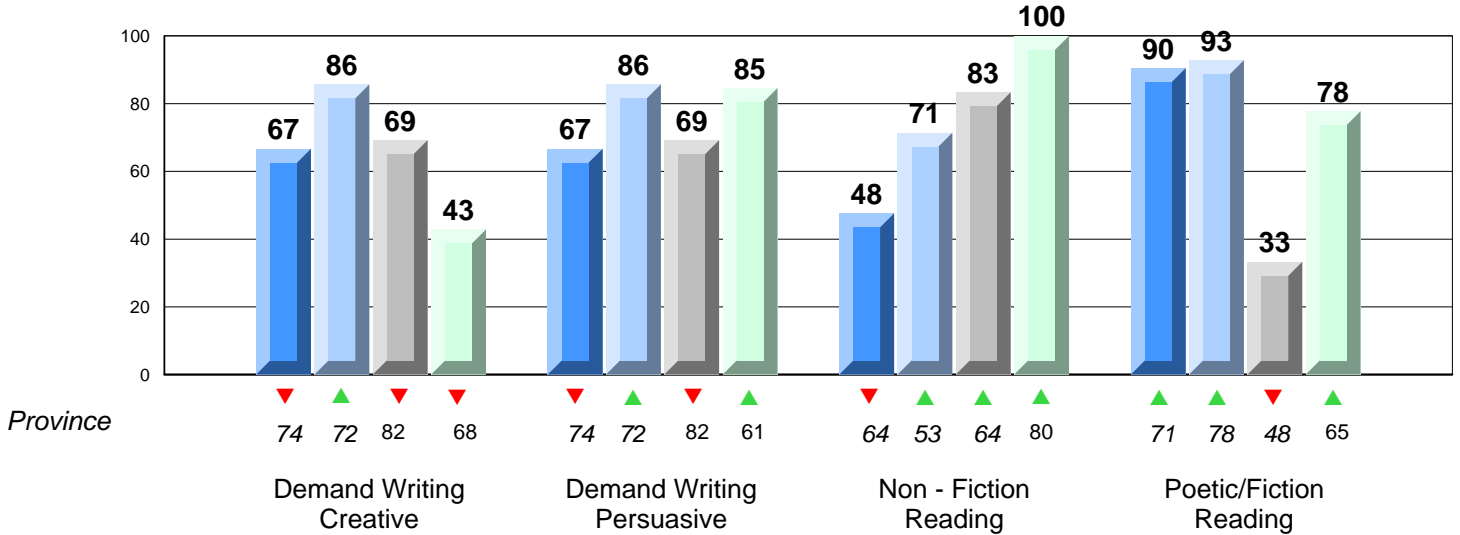

**Difference from Provincial Mean, 2010-13**

Multiple Choice

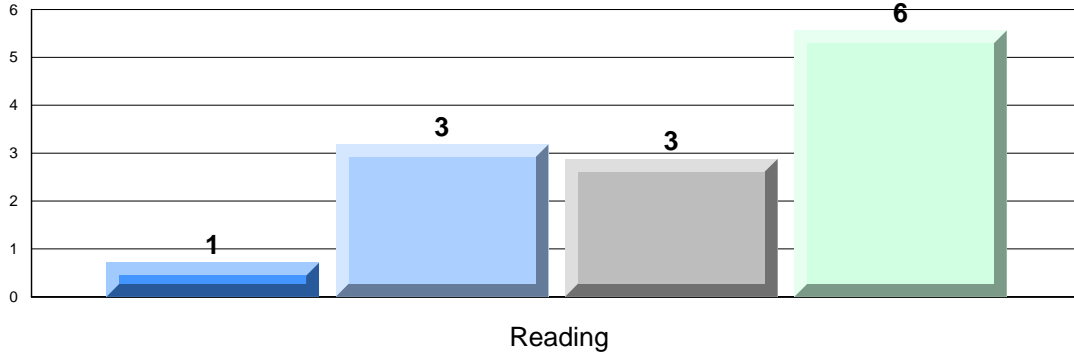

**Difference from Provincial Mean, 2010-13**

Written Response: Percentage of students meeting/exceeding grade level expectations 2010-2013

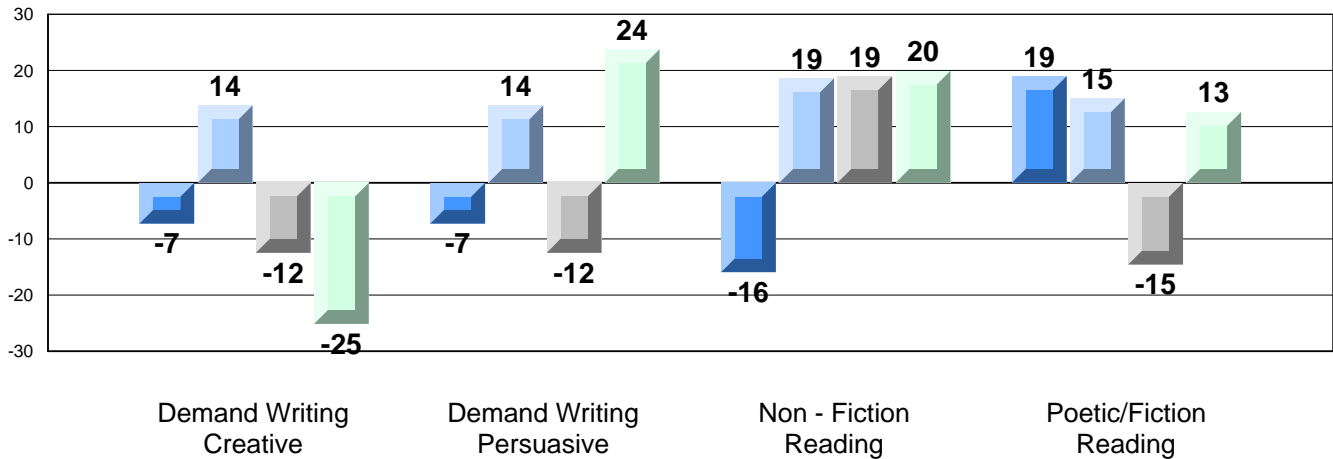

Number of Students : 82

**Multiple Choice**

**Reading**

School  
District  
Province

**Mark**

70.5  
71.4  
72.7

School  
vs  
District



School  
vs  
Province



**Closed Responses\***

**Demand Writing (Creative)**

School  
District  
Province

64.1  
66.5  
68.0



**Demand Writing (Persuasive)**

School  
District  
Province

68.4  
61.0  
60.8



**Non - Fiction Reading**

School  
District  
Province

85.5  
79.9  
80.1



**Fiction Reading**

School  
District  
Province

53.7  
62.1  
65.1



\* How to interpret the results for Closed Responses

On the Demand Writing (Creative) section, the students in Gander Academy scored 64.1%. This means 64.1% of the students met or exceeded the cut score for this section.

4 Year CRT (Subtest) Mark Trend 2010-2013  
Multiple Choice

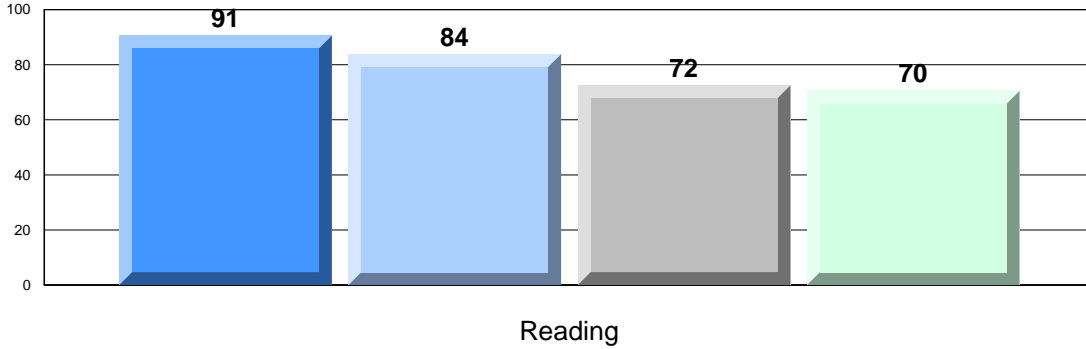

Written Response: Percentage of students meeting/exceeding grade level expectations 2010-2013

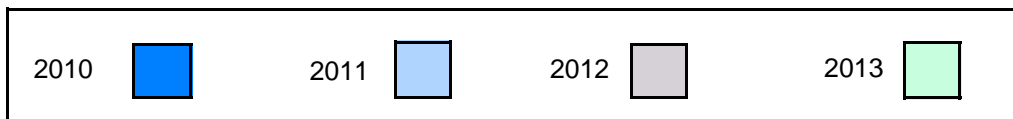
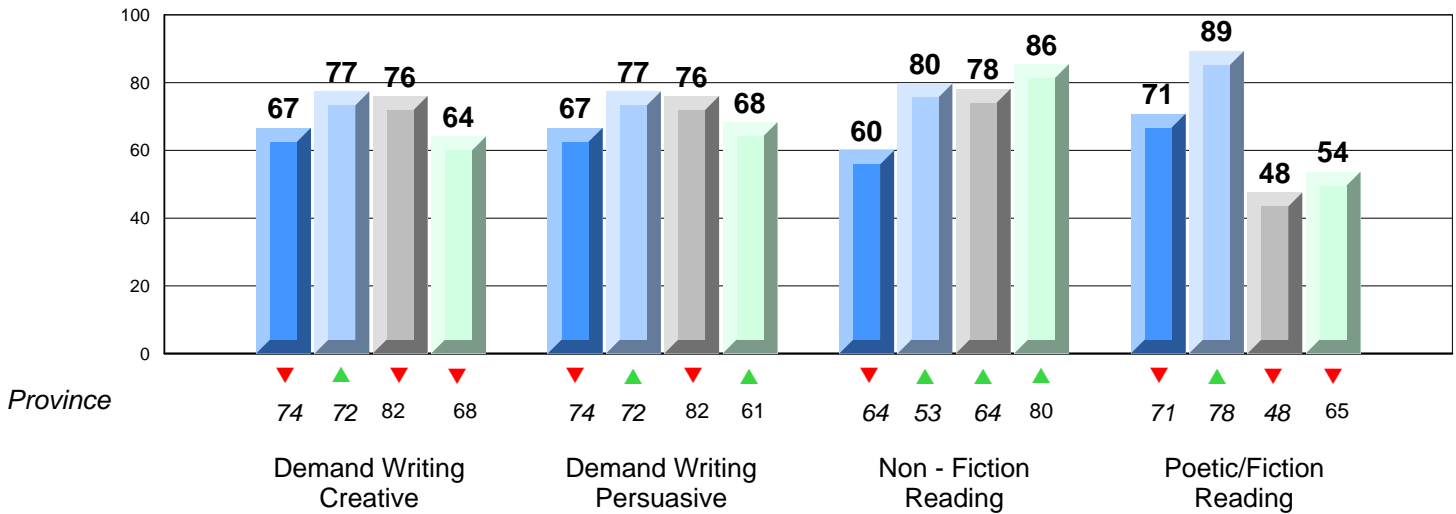

**Difference from Provincial Mean, 2010-13**

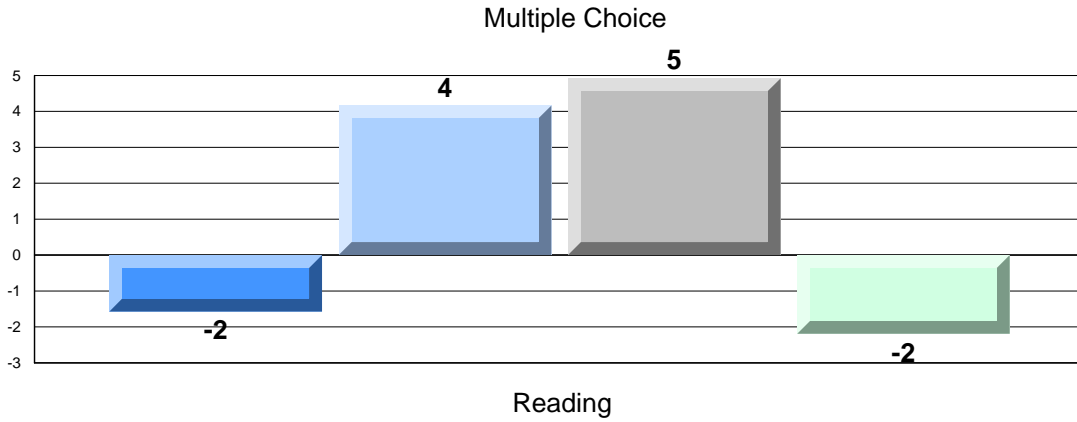

**Difference from Provincial Mean, 2010-13**

**Written Response: Percentage of students meeting/exceeding grade level expectations 2010-2013**

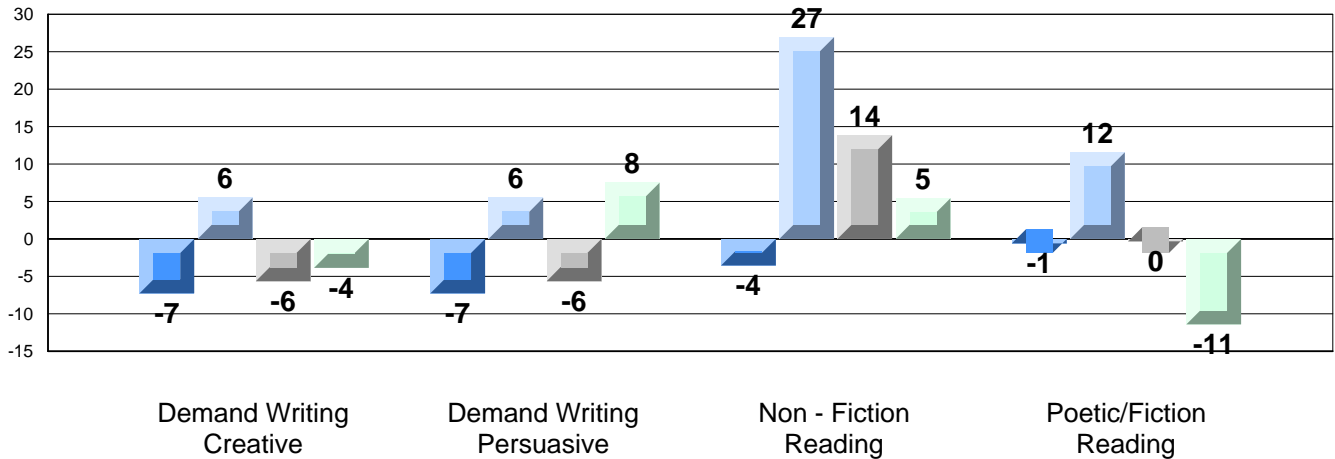

Number of Students : 21

**Multiple Choice**

**Reading**

School  
District  
Province

**Mark**

74.5  
71.4  
72.7

School  
vs  
District



School  
vs  
Province



**Closed Responses\***

**Demand Writing (Creative)**

School  
District  
Province

75.0  
66.5  
68.0



**Demand Writing (Persuasive)**

School  
District  
Province

60.0  
61.0  
60.8



**Non - Fiction Reading**

School  
District  
Province

94.7  
79.9  
80.1



**Fiction Reading**

School  
District  
Province

77.8  
62.1  
65.1



\* How to interpret the results for Closed Responses

On the Demand Writing (Creative) section, the students in Lakewood Academy scored 75.0%. This means 75.0% of the students met or exceeded the cut score for this section.

4 Year CRT (Subtest) Mark Trend 2010-2013  
Multiple Choice

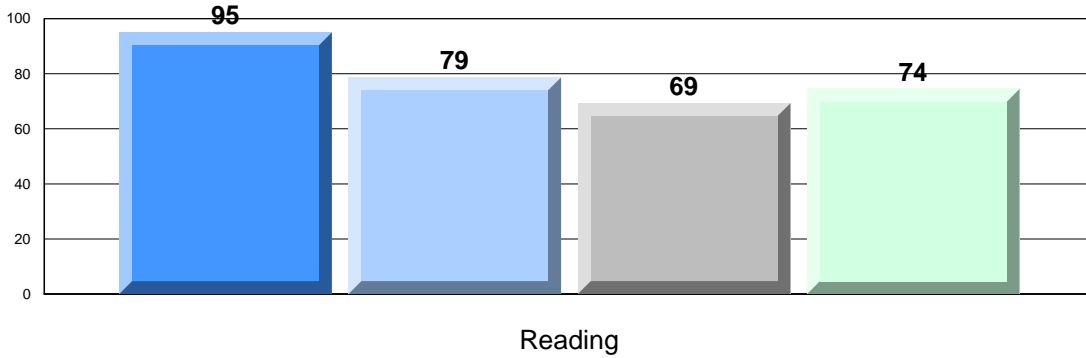

Written Response: Percentage of students meeting/exceeding grade level expectations 2010-2013

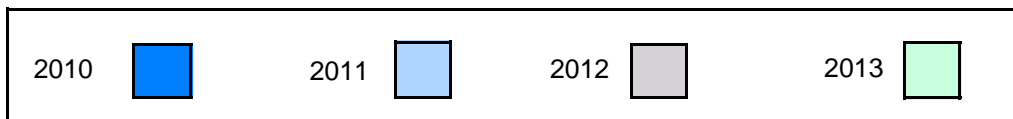
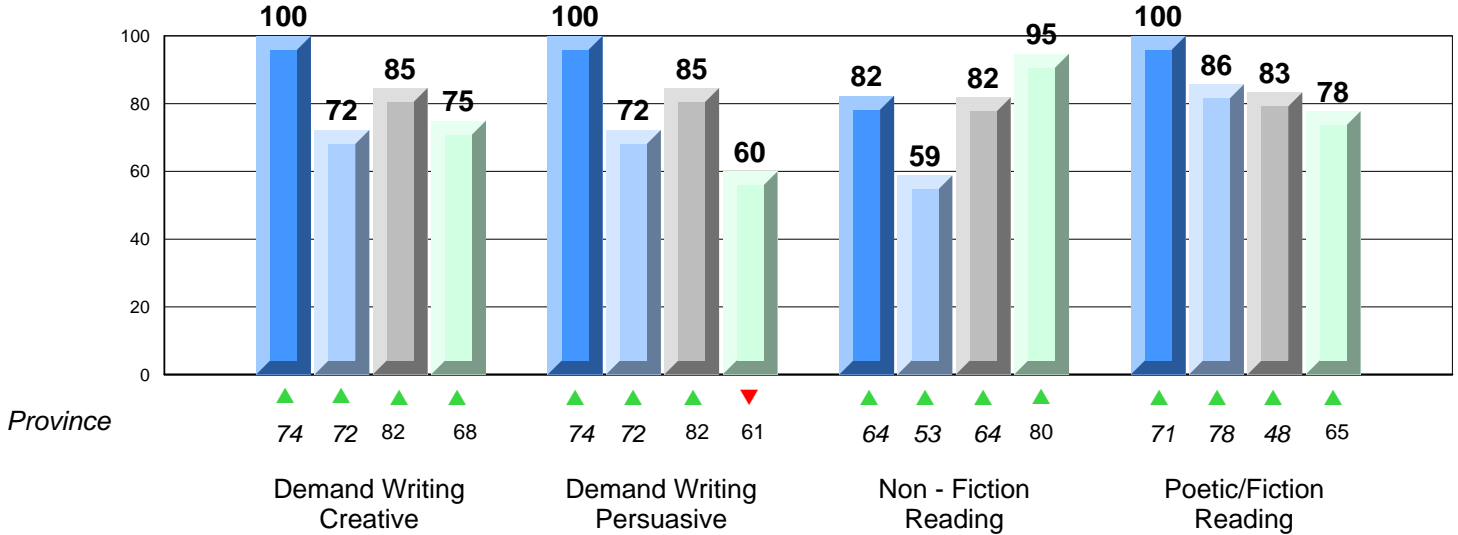



**Difference from Provincial Mean, 2010-13**

Multiple Choice

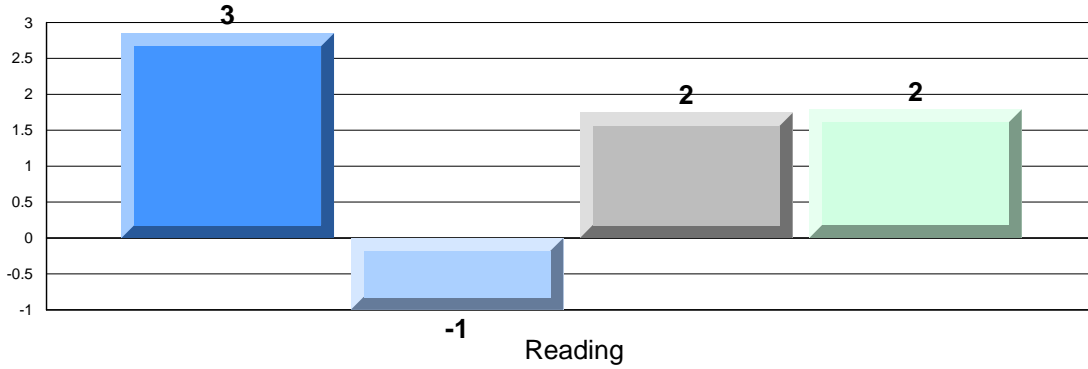

**Difference from Provincial Mean, 2010-13**

Written Response: Percentage of students meeting/exceeding grade level expectations 2010-2013

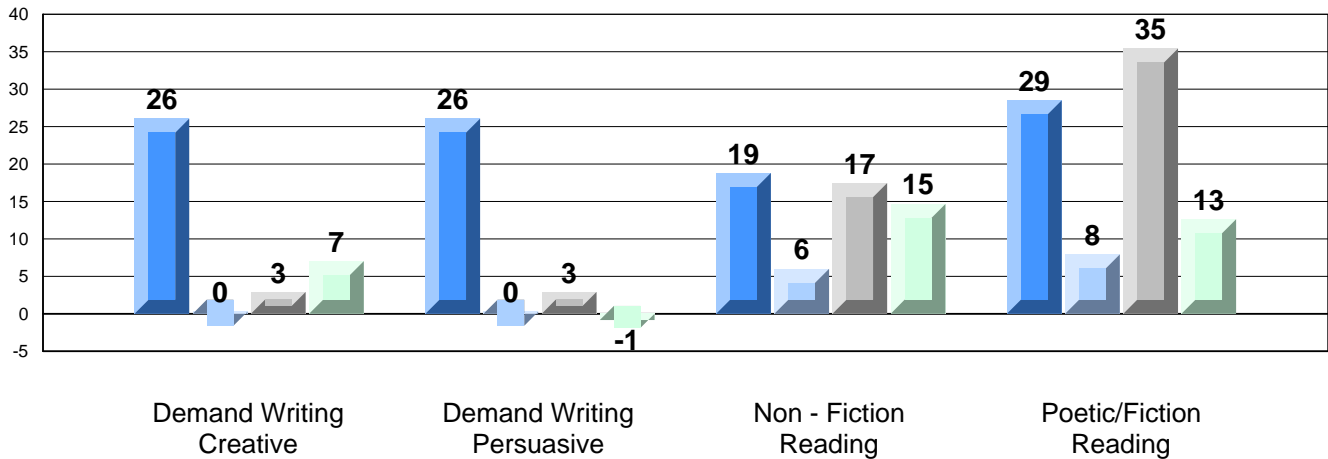

Number of Students : 17

**Multiple Choice**

**Reading**

School  
District  
Province

**Mark**

67.7  
71.4  
72.7

School  
vs  
District



School  
vs  
Province



**Closed Responses\***

**Demand Writing (Creative)**

School  
District  
Province

64.7  
66.5  
68.0



**Demand Writing (Persuasive)**

School  
District  
Province

64.7  
61.0  
60.8



**Non - Fiction Reading**

School  
District  
Province

76.5  
79.9  
80.1



**Fiction Reading**

School  
District  
Province

53.3  
62.1  
65.1



\* How to interpret the results for Closed Responses

On the Demand Writing (Creative) section, the students in Glovertown Academy scored 64.7%. This means 64.7% of the students met or exceeded the cut score for this section.

4 Year CRT (Subtest) Mark Trend 2010-2013  
Multiple Choice

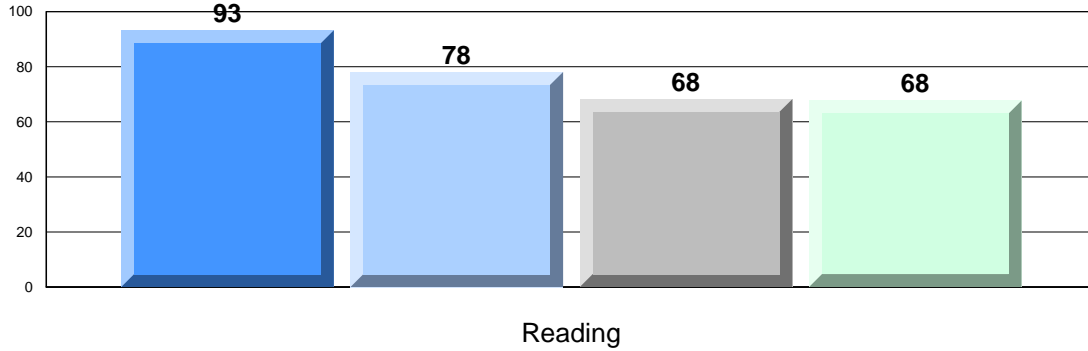

Written Response: Percentage of students meeting/exceeding grade level expectations 2010-2013

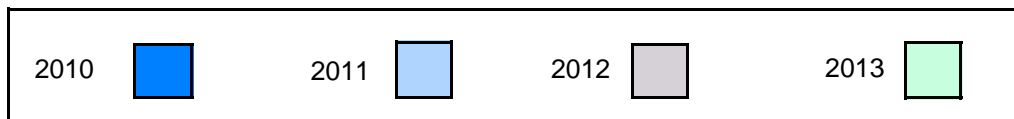
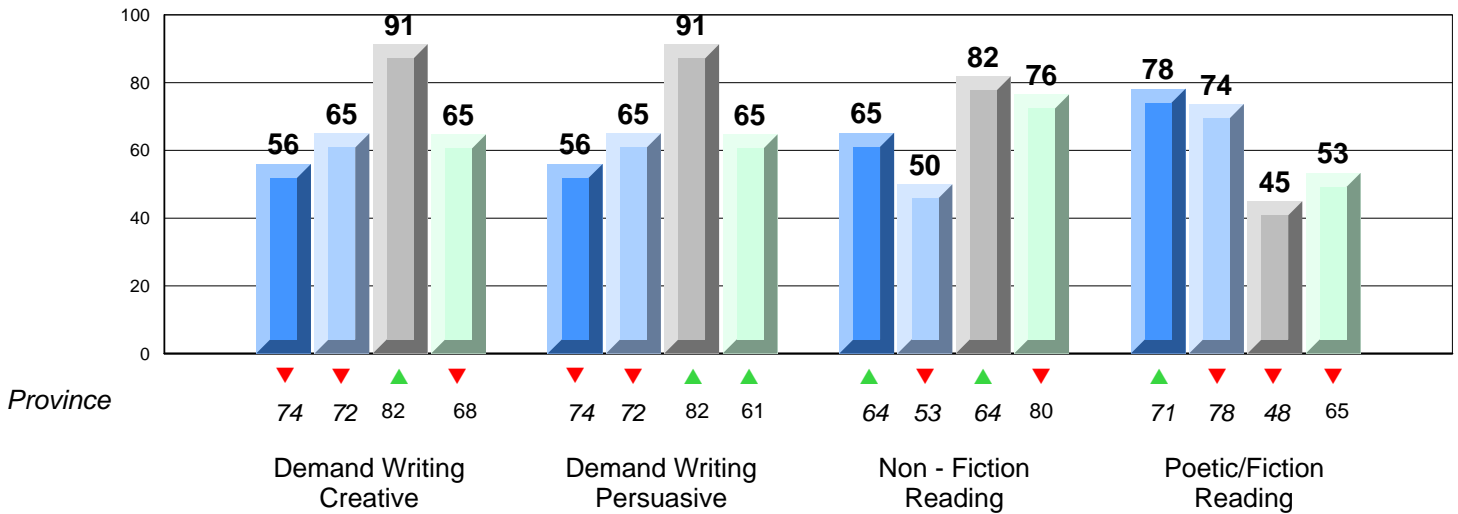

**Difference from Provincial Mean, 2010-13**

Multiple Choice

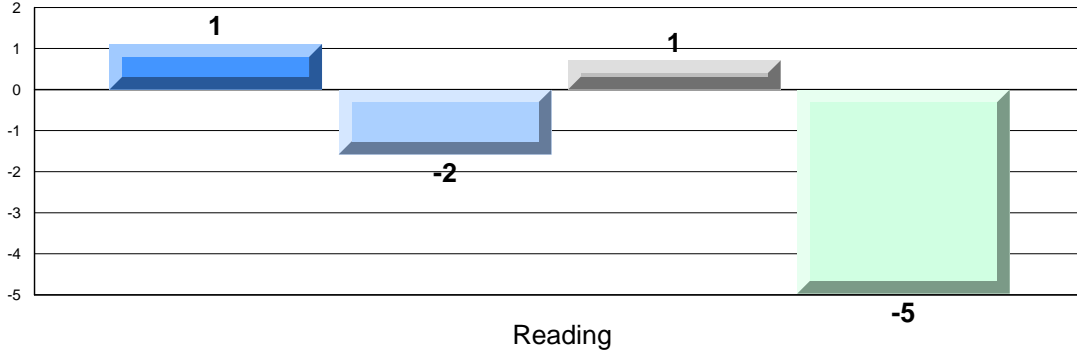

**Difference from Provincial Mean, 2010-13**

Written Response: Percentage of students meeting/exceeding grade level expectations 2010-2013

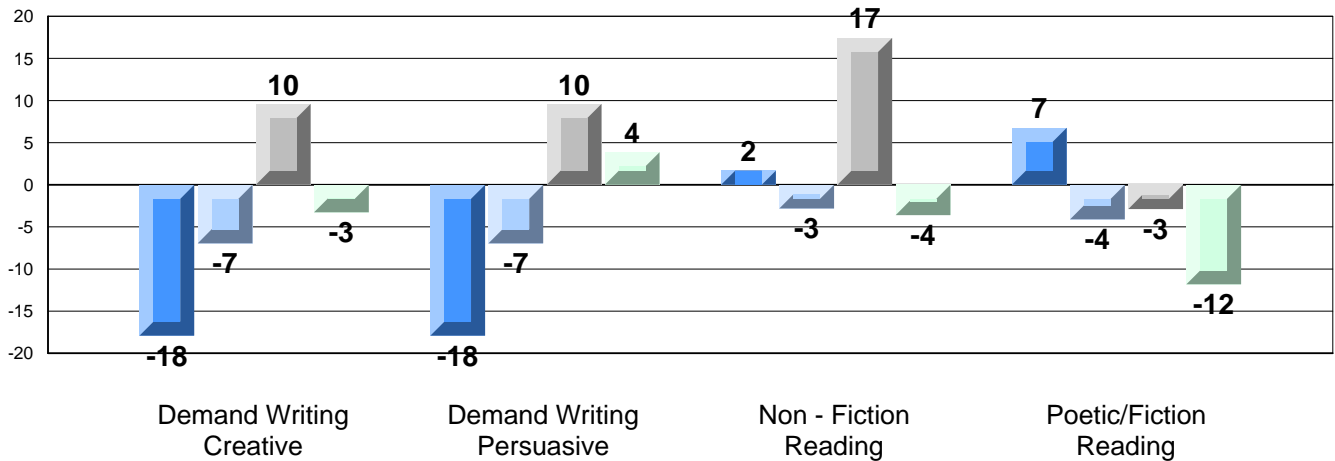

Number of Students : 11

**Multiple Choice**

**Reading**

School  
District  
Province

**Mark**

74.0  
71.4  
72.7

School  
vs  
District



School  
vs  
Province



**Closed Responses\***

**Demand Writing (Creative)**

School  
District  
Province

80.0  
66.5  
68.0



**Demand Writing (Persuasive)**

School  
District  
Province

63.6  
61.0  
60.8



**Non - Fiction Reading**

School  
District  
Province

88.9  
79.9  
80.1



**Fiction Reading**

School  
District  
Province

75.0  
62.1  
65.1



\* How to interpret the results for Closed Responses

On the Demand Writing (Creative) section, the students in Hillview Academy scored 80.0%. This means 80.0% of the students met or exceeded the cut score for this section.

4 Year CRT (Subtest) Mark Trend 2010-2013  
Multiple Choice

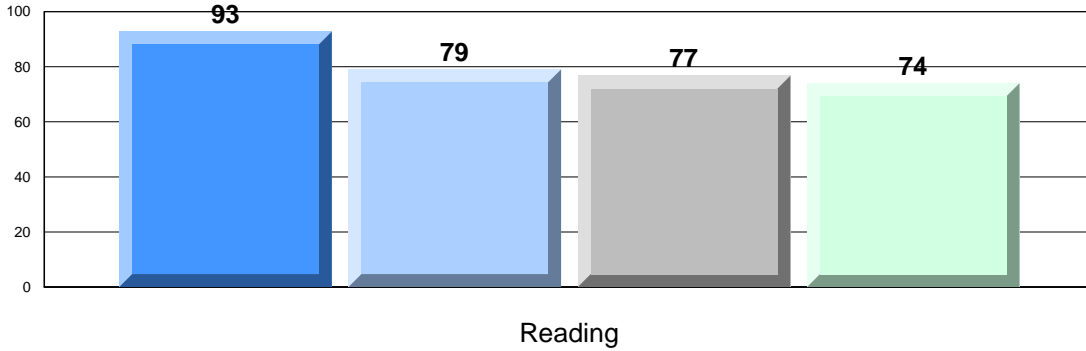

Written Response: Percentage of students meeting/exceeding grade level expectations 2010-2013

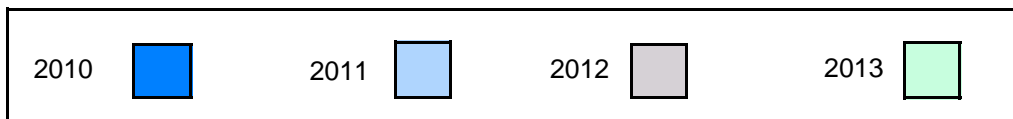
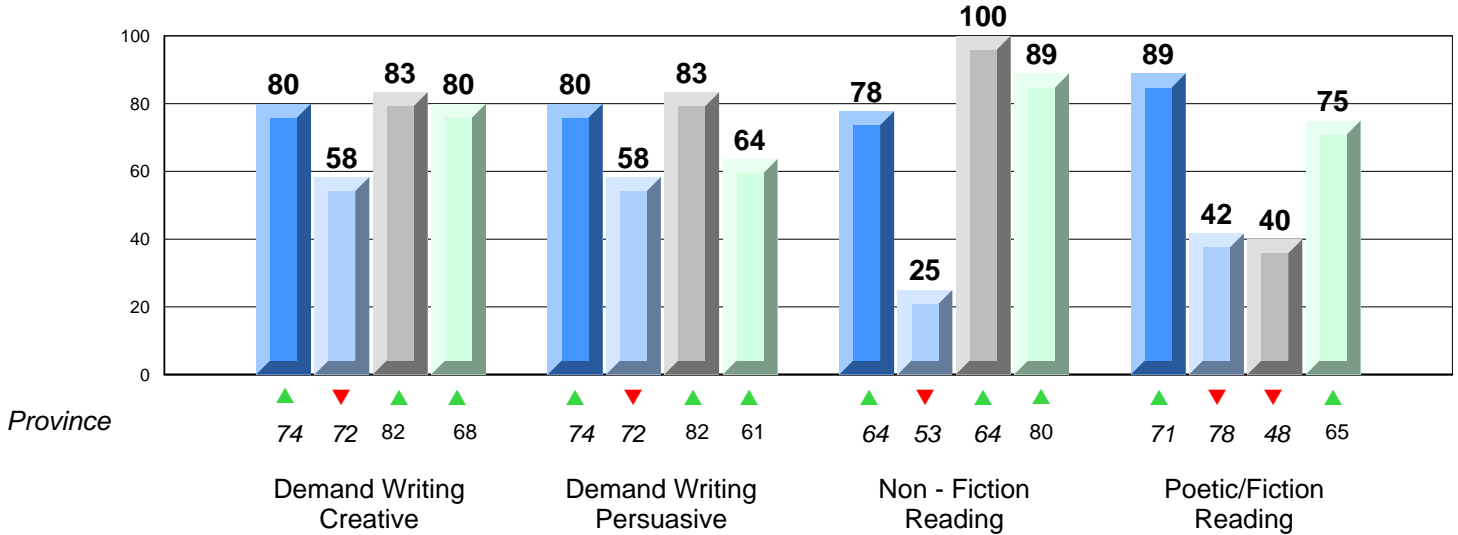

**Difference from Provincial Mean, 2010-13**

Multiple Choice

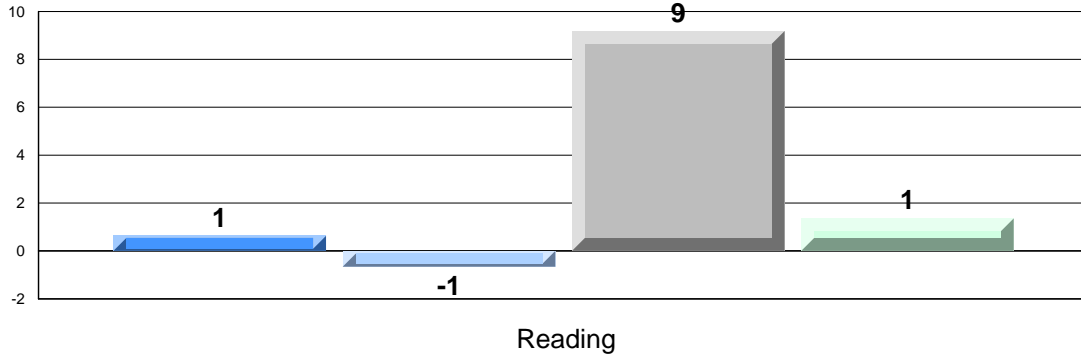

**Difference from Provincial Mean, 2010-13**

Written Response: Percentage of students meeting/exceeding grade level expectations 2010-2013

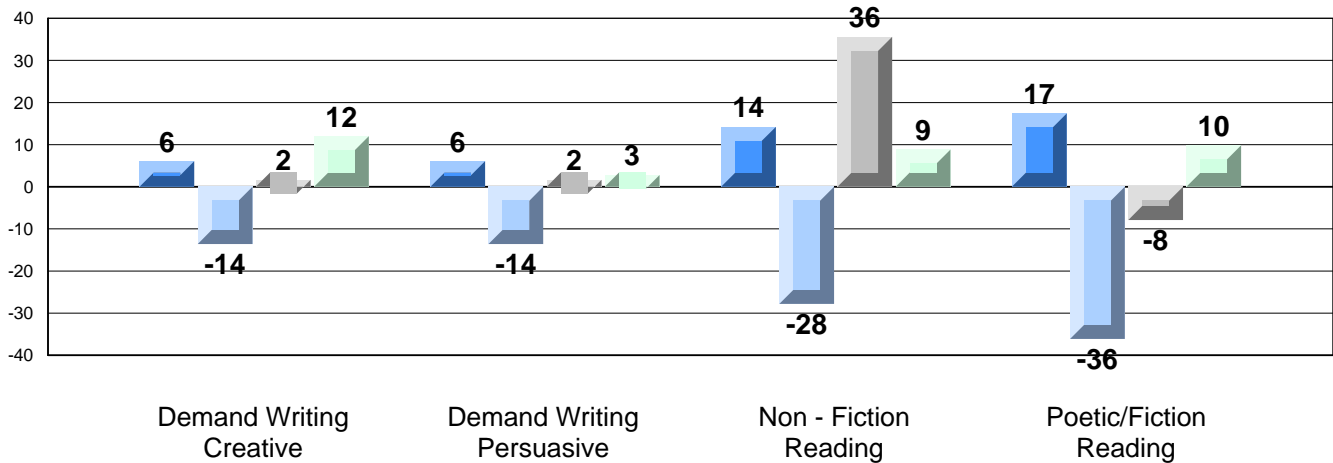

Number of Students : 17

**Multiple Choice**

**Reading**

School  
District  
Province

**Mark**

57.2  
71.4  
72.7

School  
vs  
District



School  
vs  
Province



**Closed Responses\***

**Demand Writing (Creative)**

School  
District  
Province

52.9  
66.5  
68.0



**Demand Writing (Persuasive)**

School  
District  
Province

50.0  
61.0  
60.8



**Non - Fiction Reading**

School  
District  
Province

52.9  
79.9  
80.1



**Fiction Reading**

School  
District  
Province

43.8  
62.1  
65.1



\* How to interpret the results for Closed Responses

On the Demand Writing (Creative) section, the students in New World Island Academy scored 52.9%. This means 52.9% of the students met or exceeded the cut score for this section.



4 Year CRT (Subtest) Mark Trend 2010-2013  
Multiple Choice

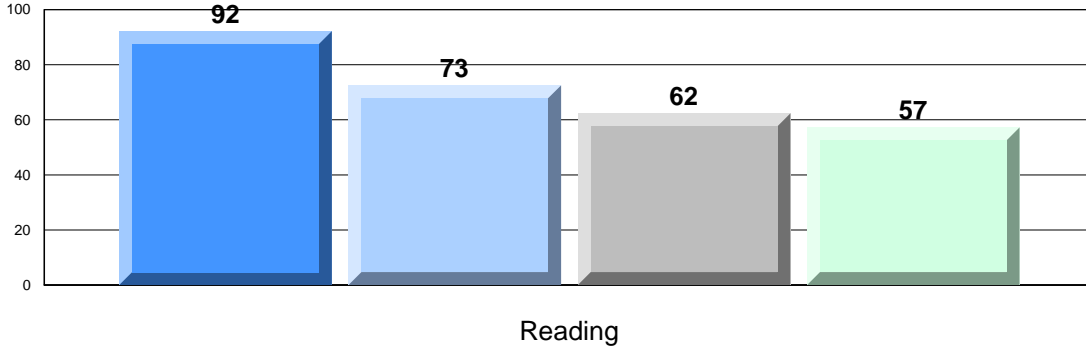

Written Response: Percentage of students meeting/exceeding grade level expectations 2010-2013

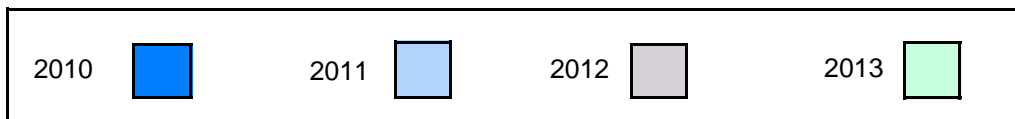
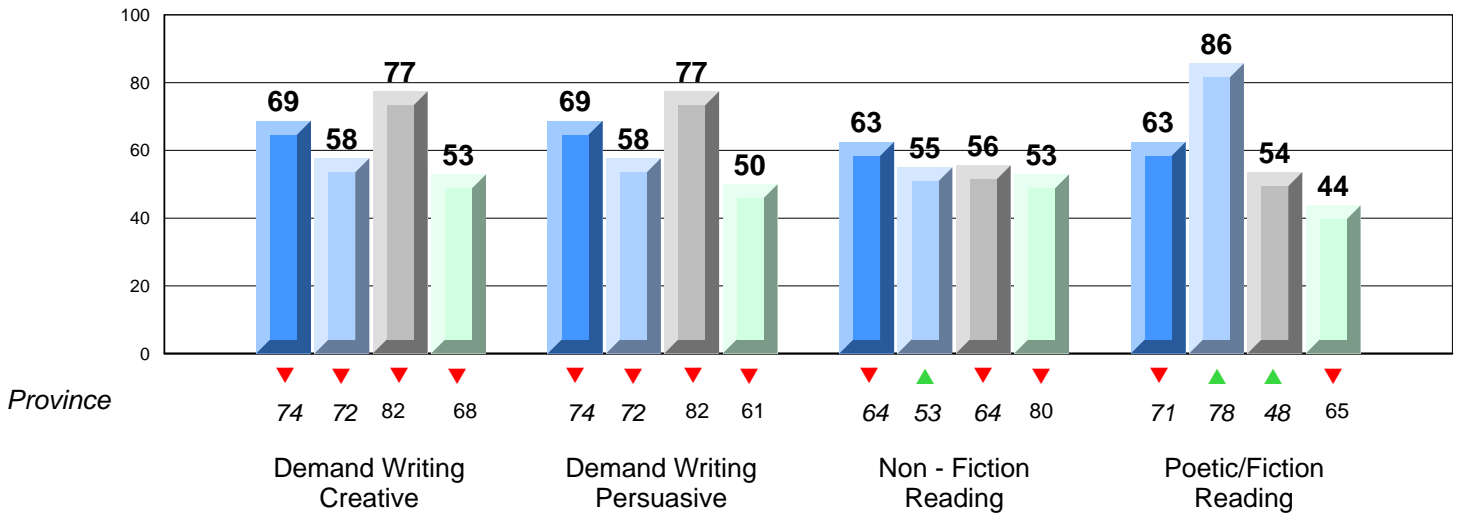

**Difference from Provincial Mean, 2010-13**

Multiple Choice

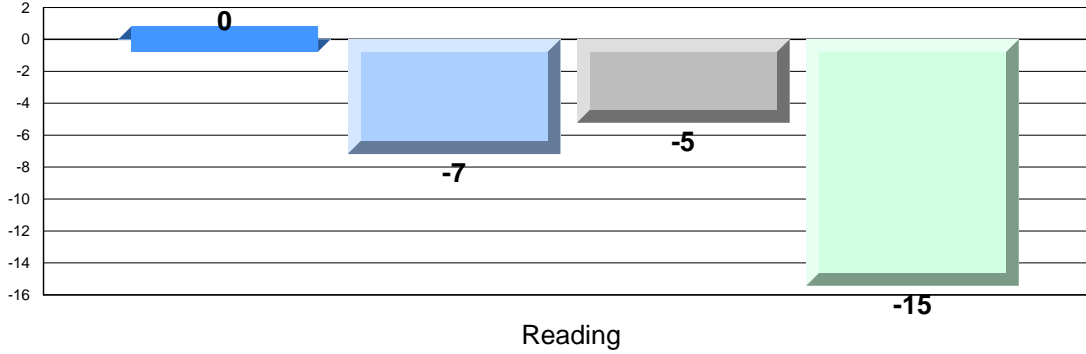

**Difference from Provincial Mean, 2010-13**

Written Response: Percentage of students meeting/exceeding grade level expectations 2010-2013

